

**For use by specialist companies only!**



Read carefully before use/installation!  
Keep for future reference!

# Move PS

Parallel sliding hardware

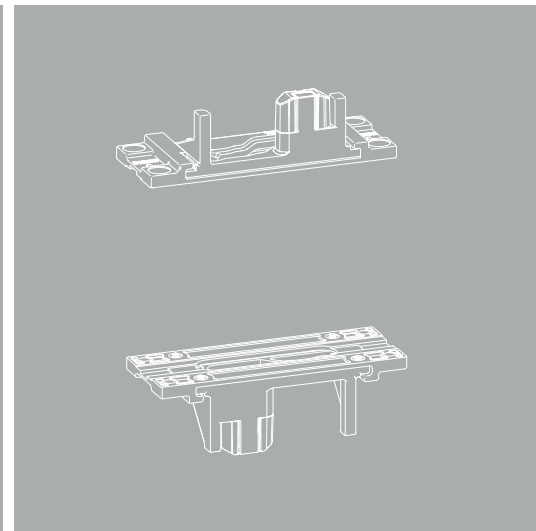
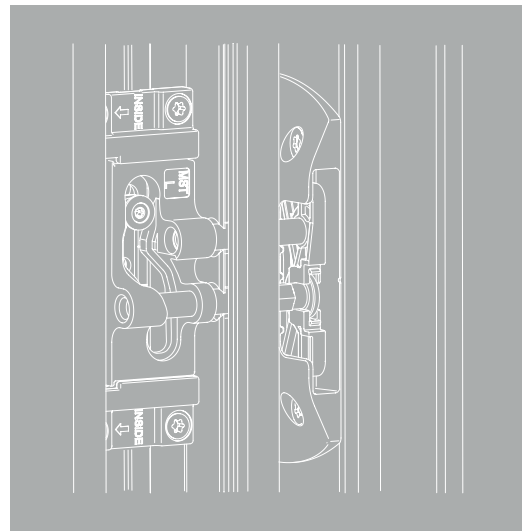
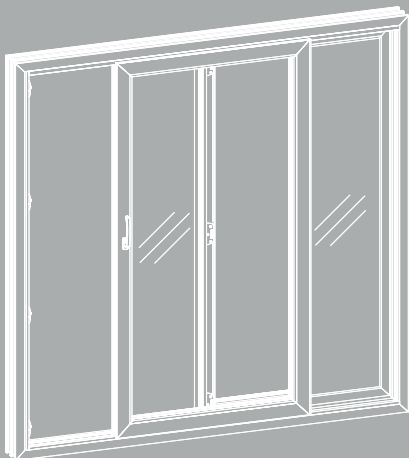

## Installation instructions

Aluplast Smart Slide

# Contents

---

Intended use, prerequisites, user information, function and safety	5
Explanation of terms, abbreviations/terms, conversion from SH/SB to SRH/SRW and SRH/SRW to SH/SB, Note for elements with increased security requirements	6
Areas of use, attachment screws	7
Scheme A/C single sash packaging units	8
Overview of the fitting parts and tools required for Scheme A/C single sash	9
Scheme C double sash packaging units	10
Overview of the fitting parts and tools required for Scheme C double sash	11
Preparation of sash frame	12
Mounting on the sash	15
Cutting rails to length and installing central locking gear	15
Handle, top/lower locking devices, bogies, guides	17
Positioning drilling template for locking devices MST on the non-handle side	20
Cutting additional profiles to length/installing, Scheme A	22
Cutting additional profiles to length/installing, Scheme C	23
Installing strikers	24
Installing the sash	26

---

## Contents (contd.)

---

Correcting the position of strikers on handle side, checking inlet of locking devices MST	28
Positioning the drilling template for strikers on the handle side	29
Fitting the top stopper	30
Installing the sash buffer	31
Fitting optional top sash buffer	32
Fitting optional recess handle	34
Fitting optional handle 161 GE-Pcl/160 GE-PcO	35
Sash contact pressure adjustment	38
Overview of vertical cross-section	39
Horizontal cross-section of handle	40
Horizontal cross-section of central stile	41
Vertical cross-section of top guide	42
Vertical cross-section of bogie	43
Vertical cross-section of top locking device(s)	44
Vertical cross-section of lower locking device(s)	45
Horizontal section Scheme C	46

---



## Intended use

Move PS parallel-slide fittings are only intended for use in non-portable buildings. They are used to open and close windows and patio doors horizontally. Panels must be installed perpendicular and under no circumstances in an inclined position.

## Prerequisites

- These installation instructions and the installation of the fittings require specialist knowledge acquired during completed training in at least one of the following occupations: joiner, metal worker for construction technology, window and glass façade builder.
- The areas of use specified on page 7 apply to Move PS fittings. Specifications for screw-in speeds and torques are binding.
- Use **sufficiently long screws** to fasten **the fitting parts**. They must reach as far as **the steel reinforcement** in PVC profiles.
- **Follow the profile manufacturer's processing guidelines each time.**
- You must not paint the frame profile or the guide and running tracks.
- The panels may **only** be surface-treated before fitting parts are installed. Subsequent surface treatment can limit the correct functioning of fitting parts. In such cases, any warranty claims against the hardware manufacturer are void.
- The steel fitting parts described in these assembly instructions are clear-passivated and sealed as per EN 12329. They must not be used in environments with aggressive or corrosive airborne substances.
- Keep the running track and all joints free of deposits and dirt to prevent damage to the fitting and ensure optimum function. **Protect the fitting, especially against cement or plaster residues.**
- Do not use acid-curing sealants as these can cause corrosion to the fitting parts.
- Use acid- and solvent-free oils and greases.
- Avoid exposing the fittings directly to moisture and ensure the fitting does not come into contact with acidic cleaning agents.
- The hardware manufacturer is not liable for any malfunctions or damage to the hardware and windows or patio doors installed with the fitting if these are due to combined use with other fitting parts, an inadequate tendering procedure and non-observance of the installation instructions or application diagrams.
- The fabricator is responsible for ensuring observance of the functional dimensions specified in these installation instructions, flawless installation of fittings and secure fastening of all components.

## User information

- Give the end user the maintenance and operating instructions for end users on delivering the product.
- Position the operating label (slide direction DIN left or DIN right) so it is clearly visible on the installed window sash. In the case of the MULTI-MATIC central locking gear, you will find the operating label in the "Move PS" basic box.
- **Observe the "Guidelines/advice on the product and on liability (VHBH)". Inform the end user about the contents of the "Guidelines/advice for end users (VHBE)".**
- Keep these installation instructions in a safe place.

## Function and safety

- The maximum permissible deflection in the bottom frame is 3 mm to ensure the panel functions correctly and is safe.
- Shim the threshold at least every 300 mm throughout the entire construction depth.

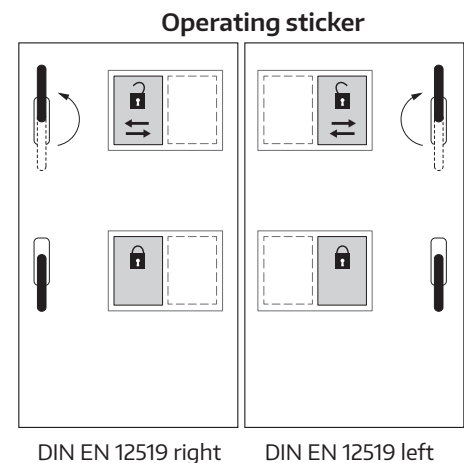
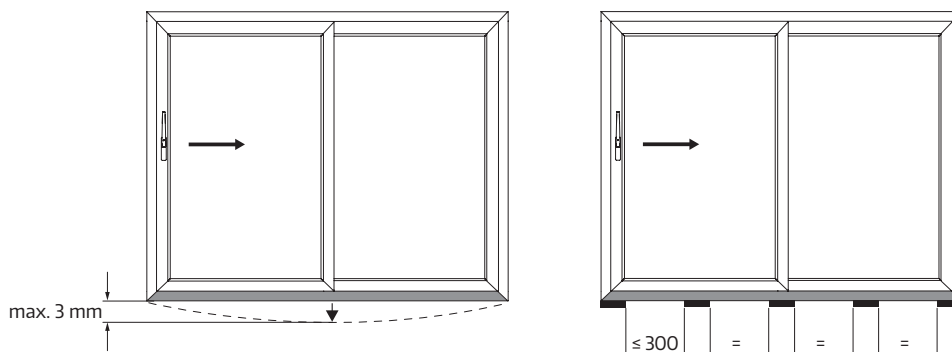

## Explanation of terms

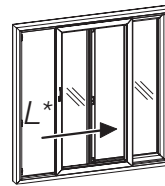
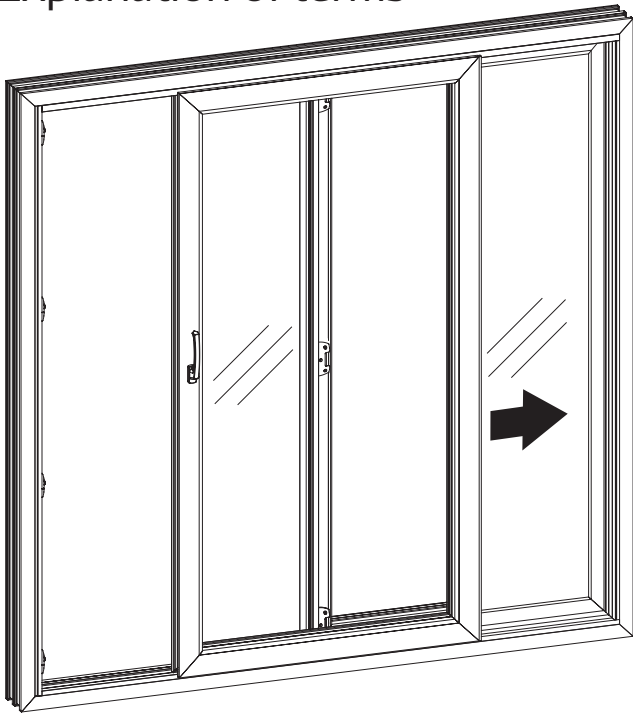

\* Left-hand version  
= DIN EN 12519 right  
(opens to right)

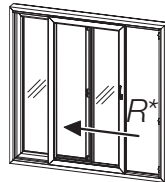

\* Right-hand version  
= DIN EN 12519 left  
(opens to left)

The images in these installation instructions refer to the left-hand version (DIN EN 12519 right).

These measurements must be applied in reverse when using the right-hand version (DIN EN 12519 left).

All measurements in these instructions are in millimetres (mm).

### IMPORTANT:

- These instructions describe how to install the MULTI-MATIC central locking gear. If a locking device by another manufacturer is used, cutting to length, mounting dimensions, drilling and similar must be carried out according to the locking device manufacturer's instructions.
- These instructions describe all installation steps for installing a Move PS element.
- The fitting must be greased/oiled before it is put into use (see Maintenance and operating instructions).

## Abbreviations/terms

FPW	frame profile width	SI	Size
FPH	frame profile height	GE handle	Handle for gearbox espag
B	Backset	GE-S handle	Handle for gearbox espag, lockable
GE	Gearbox espag	FFL	Finished floor level
SB	Sash width	PcO	Profile cylinder, outside
SRW	Sash rebate width	PcI	Profile cylinder, inside
SRH	Sash rebate height	RC 2	Resistance class 2
SRE	Sash rebate edge		
SW	Sash weight		
SH	Sash height		

## Conversion from SH/SB to SRH/SRW

SRH = SH - 70  
SRW = SB - 70

## Conversion from SRH/SRW to SH/SB

SH = SRH + 70  
SB = SRW + 70

## Note for elements with increased security requirements

The basis for the RC 2 version is the burglar resistance fitting matrix from MACO Systemtechnik EH. For the RC 2 version, Günther Aichinger Systemtechnik EH must be contacted.

## Areas of use

The limits to areas of use specified here are binding and must not be exceeded. Also observe the permitted application sizes, production instructions and processing guidelines as specified by the profile manufacturers.

### Move PS

Sash rebate width (SRW) [mm]	Scheme A : Scheme C : Twin:	650 to 2000 (SW ≤ 200 kg) 650 to 1430 (SW ≤ 200 kg) 1230 to 2000 (SW > 200– 250 kg)
Sash rebate height (SRH) [mm]	530 to 2230	
Sash weight (SW) [kg]	max. 200/250	

SRH: SRW = max. 2: 1

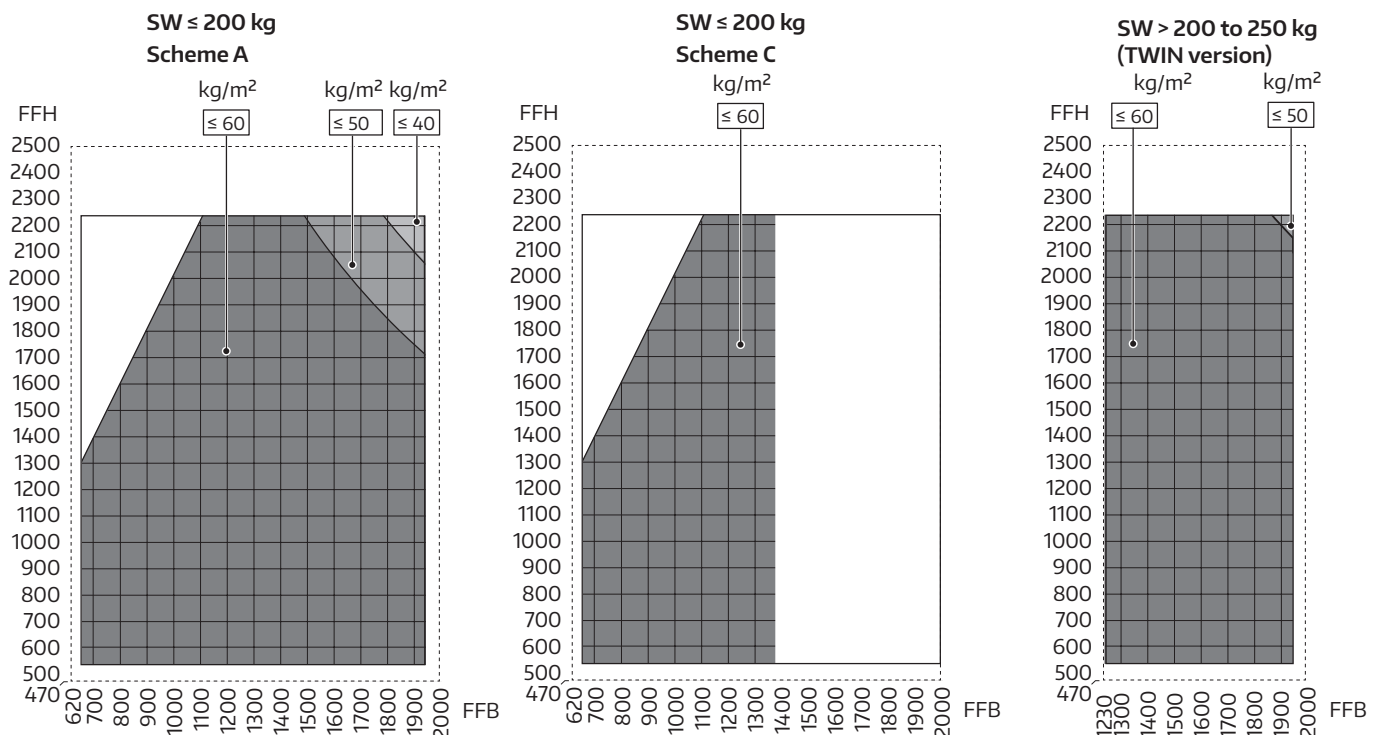

## Attachment screws for fitting parts (not included in the scope of supply)

for component(s)	Number	Size	Drilling diameter	Drive
Bogie (10)	8/16	4.0 x 22 <sup>4</sup>	3.2	Freely selectable
Central locking gear (12, 13, 14, 15, 16)	... <sup>1</sup>	4.0 x ... <sup>2</sup>	-	
Locking device top (3)/locking device bottom (11)	8– 24	4.0 x 22 <sup>4</sup>	3.2	
Locking device MST (7)	4– 12	4.0 x 22 <sup>4</sup>	3.2	
Striker MST (8)	3– 9	4.8 x 28 <sup>5</sup>	4.2	
Guide top, left (1) / guide top, right (2)	8	4.0 x 22 <sup>4</sup>	3.2	
Espag hold-down device (26) <sup>6</sup>	1	4.0 x 22 <sup>4</sup>	3.2	
Buffer stop scheme C (27)	2	4,0 x ... <sup>2</sup>	3.2	
Running/guide/frame profile (supplied by customer; not included in scope of supply)	... <sup>3</sup>	4.0 x 22 <sup>4</sup>	3.2	
Cover rail shim (supplied by customer; not included in scope of supply)	4	4.0 x 50	-	

<sup>1</sup>) Depends on lock

<sup>2</sup>) The length must be selected based on the profiles used

<sup>3</sup>) Depends on the panel size

<sup>4</sup>) Self-tapping screws with a countersunk head 3.9 x 25 can be used as an alternative

<sup>5</sup>) Self-tapping screws with a countersunk head 4.8 x 32 can be used as an alternative

<sup>6</sup>) For short espags without screw holes only

Scheme A

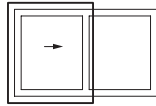

Scheme C: Single sash

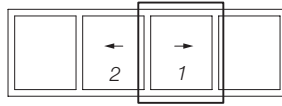

## Scheme A/C single sash packaging units

	<p><b>1</b> 1x</p> <p><b>2</b> 1x</p>	<p><b>3</b> 1x</p> <p><b>11</b> 1x</p>	<p><b>4</b> 2x</p> <p><b>5</b> 2x</p>	<p>Maintenance and operating instructions</p> <p>Operating sticker</p>						
	<p><b>8</b></p> <table border="1"> <thead> <tr> <th>FFH</th> <th>8</th> </tr> </thead> <tbody> <tr> <td>470 ... 1150 mm</td> <td>2x</td> </tr> <tr> <td>1151 ... 2360 mm</td> <td>3x</td> </tr> <tr> <td>2361 ... 2500 mm</td> <td>4x</td> </tr> </tbody> </table>	FFH	8	470 ... 1150 mm	2x	1151 ... 2360 mm	3x	2361 ... 2500 mm	4x	
FFH	8									
470 ... 1150 mm	2x									
1151 ... 2360 mm	3x									
2361 ... 2500 mm	4x									
<p>FG &gt; 200 kg</p>	<p><b>10</b> 2x</p>									
	<p><b>6</b> 2x</p> <p><b>7</b> 2x</p> <table border="1"> <thead> <tr> <th>FFH</th> <th>6</th> <th>7</th> </tr> </thead> <tbody> <tr> <td>1151 ... 2360 mm</td> <td>1x</td> <td></td> </tr> <tr> <td>2361 ... 2500 mm</td> <td>2x</td> <td></td> </tr> </tbody> </table>	FFH	6	7	1151 ... 2360 mm	1x		2361 ... 2500 mm	2x	
FFH	6	7								
1151 ... 2360 mm	1x									
2361 ... 2500 mm	2x									
	<p><b>4</b> 2x</p> <p><b>5</b> 2x</p> <table border="1"> <thead> <tr> <th>FFH</th> <th>4</th> <th>5</th> </tr> </thead> <tbody> <tr> <td>901 ... 1700 mm</td> <td>1x</td> <td></td> </tr> <tr> <td>1701 ... 2500 mm</td> <td>2x</td> <td></td> </tr> </tbody> </table>	FFH	4	5	901 ... 1700 mm	1x		1701 ... 2500 mm	2x	
FFH	4	5								
901 ... 1700 mm	1x									
1701 ... 2500 mm	2x									
	<table border="1"> <thead> <tr> <th>FFB</th> <th>3</th> <th>11</th> </tr> </thead> <tbody> <tr> <td>1151 ... 1870 mm</td> <td>1x</td> <td></td> </tr> <tr> <td>1871 ... 2000 mm</td> <td>2x</td> <td></td> </tr> </tbody> </table> <p><b>3</b> 1x</p> <p><b>11</b> 2x</p>	FFB	3	11	1151 ... 1870 mm	1x		1871 ... 2000 mm	2x	
FFB	3	11								
1151 ... 1870 mm	1x									
1871 ... 2000 mm	2x									
	<p><b>13</b> 4x</p> <p><b>14</b> 2x</p> <p><b>15</b> 2x</p> <p><b>26</b> 1x</p>									
	<p><b>161 EG</b> 17</p> <p><b>161 EG-S</b> 18</p> <p><b>12</b> 1x</p> <p><b>16</b> 1x</p> <p><b>15</b> FFH &gt; 2400 mm</p> <p><b>15</b> FFH 1401 ... 1870 mm: 1x</p> <p><b>15</b> FFH 2111 ... 2360 mm: 1x</p> <p><b>15</b> FFH 1871 ... 2360 mm: 1x</p> <p><b>15</b> FFH &gt; 2360 mm: 2x</p>									



Scheme A

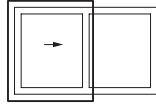

Scheme C: Single sash

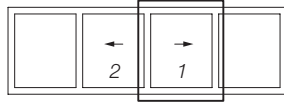

# Overview of the fitting parts for Scheme A/C single sash

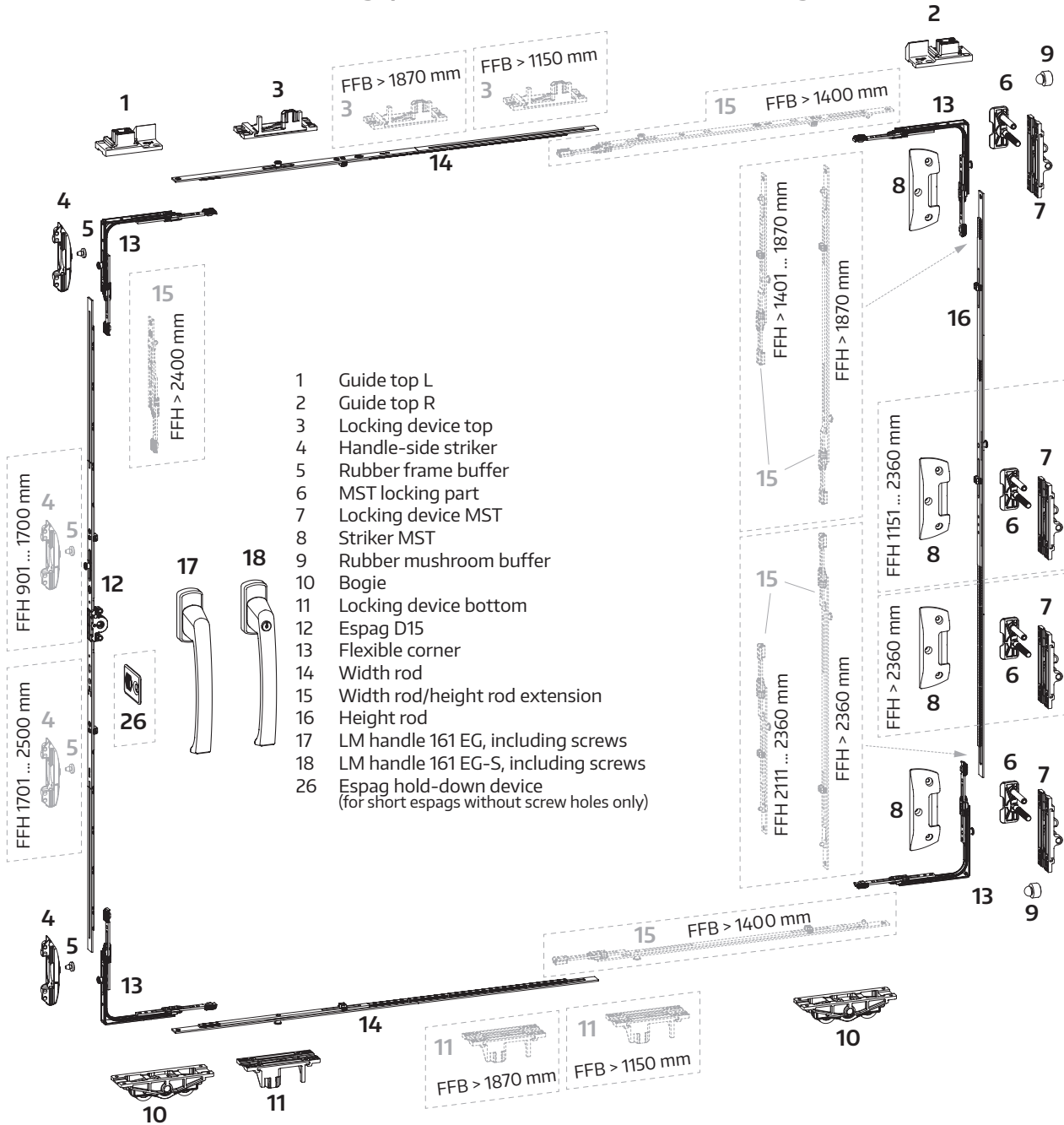

## Required tools

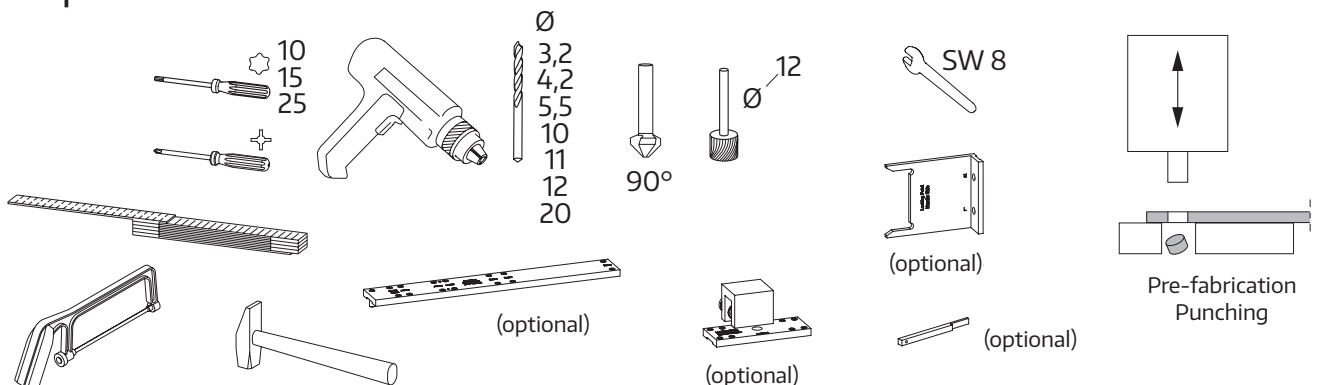

Scheme C: Double sash

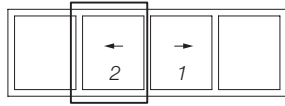

Scheme C double sash packaging units

	<p>1x 1x</p>	<p>2x 2x</p>	<p>2x 2x</p>									
	<p>2x</p>	<p>2x</p>	<p>Maintenance and operating instructions</p> <p>Operating sticker</p>									
	<table border="1"> <thead> <tr> <th>FFH</th> <th>8</th> </tr> </thead> <tbody> <tr> <td>470 ... 1150 mm</td> <td>2x</td> </tr> <tr> <td>1151 ... 2360 mm</td> <td>3x</td> </tr> <tr> <td>2361 ... 2500 mm</td> <td>4x</td> </tr> </tbody> </table>	FFH	8	470 ... 1150 mm	2x	1151 ... 2360 mm	3x	2361 ... 2500 mm	4x			
FFH	8											
470 ... 1150 mm	2x											
1151 ... 2360 mm	3x											
2361 ... 2500 mm	4x											
<p>FG &gt; 200 kg</p>	<p>2x</p>											
	<table border="1"> <thead> <tr> <th>FFH</th> <th>6</th> <th>7</th> </tr> </thead> <tbody> <tr> <td>1151 ... 2360 mm</td> <td></td> <td>1x</td> </tr> <tr> <td>2361 ... 2500 mm</td> <td></td> <td>2x</td> </tr> </tbody> </table>	FFH	6	7	1151 ... 2360 mm		1x	2361 ... 2500 mm		2x		
FFH	6	7										
1151 ... 2360 mm		1x										
2361 ... 2500 mm		2x										
	<p>1x 1x</p>		<p>1x 1x</p>									
	<table border="1"> <thead> <tr> <th>FFB</th> <th>3</th> <th>11</th> </tr> </thead> <tbody> <tr> <td>1401 ... 1870 mm</td> <td>1x</td> <td></td> </tr> <tr> <td>1871 ... 2000 mm</td> <td></td> <td>2x</td> </tr> </tbody> </table>	FFB	3	11	1401 ... 1870 mm	1x		1871 ... 2000 mm		2x		<p>FFH &gt; 2400 mm</p> <p>FFH 1401 ... 1870 mm: 1x FFH 2111 ... 2360 mm: 1x</p>
FFB	3	11										
1401 ... 1870 mm	1x											
1871 ... 2000 mm		2x										
	<p>4x 2x 2x 1x</p> <p>FFB &gt; 1400 mm</p>											
	<p>17 18</p>	<p>FFH 1871 ... 2360 mm: 1x FFH &gt; 2360 mm: 2x</p>										

Scheme C: Double sash

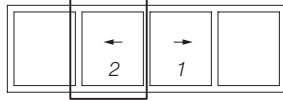

Overview of the fitting parts for Scheme C double sash

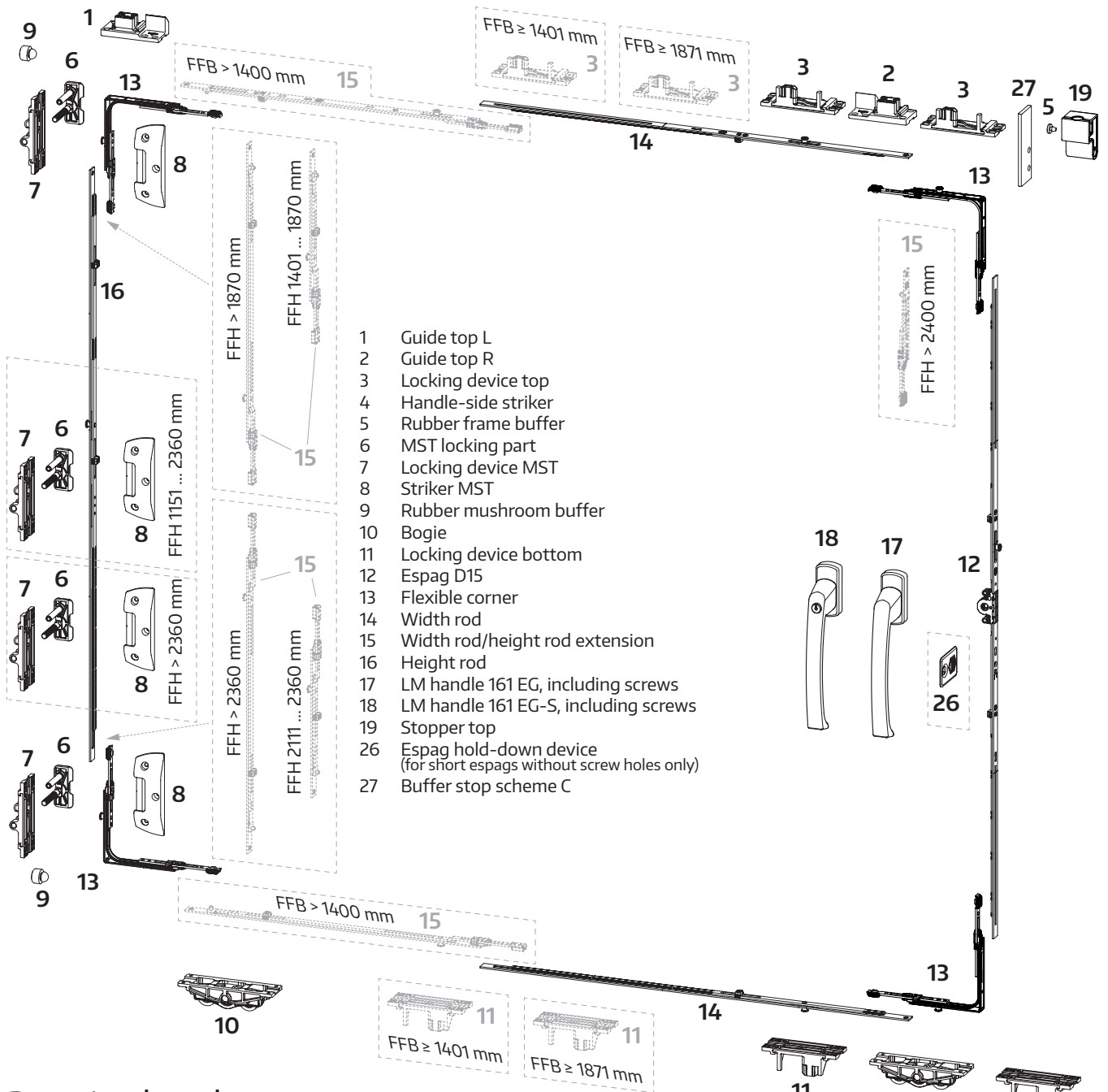

- 1 Guide top L
- 2 Guide top R
- 3 Locking device top
- 4 Handle-side striker
- 5 Rubber frame buffer
- 6 MST locking part
- 7 Locking device MST
- 8 Striker MST
- 9 Rubber mushroom buffer
- 10 Bogie
- 11 Locking device bottom
- 12 Espag D15
- 13 Flexible corner
- 14 Width rod
- 15 Width rod/height rod extension
- 16 Height rod
- 17 LM handle 161 EG, including screws
- 18 LM handle 161 EG-S, including screws
- 19 Stopper top
- 26 Espag hold-down device (for short espags without screw holes only)
- 27 Buffer stop scheme C

Required tools

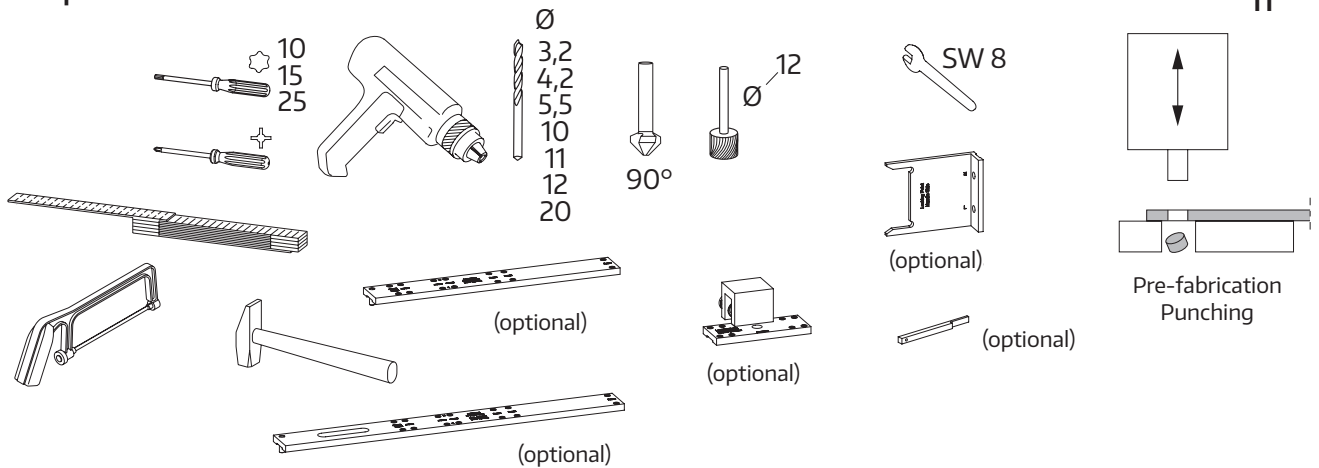

# Preparation of sash frame

## Handle drill holes and gear cut-out (161 GE/162 GE)\*

- (1) Mark the drill hole and drill with  $\varnothing 12$ .
- (2) Make the cut-out for the espag case (see detail).

\*) See separate paragraphs for handle 161 GE-Pcl/160 GE-PcO or recess handle

SRH	Handle height (rebate)
470- 800	1/2 SRH
801- 1250	1/2 SRH
1251- 1350	1/2 SRH
1351- 1540	544.5
1541- 1650	644.5
1651- 1900	994.5
1901- 2150	994.5
2151- 2400	994.5
2401- 2500	994.5

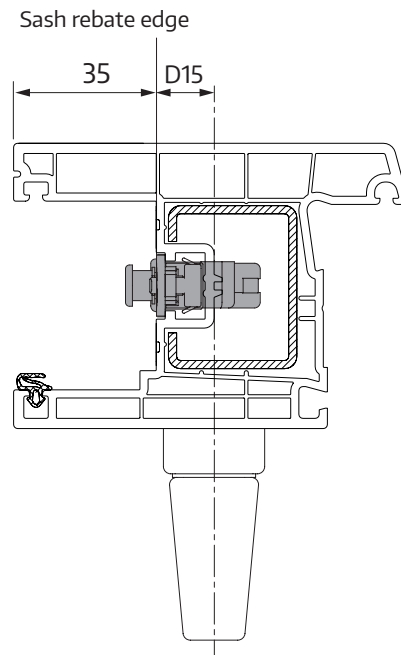
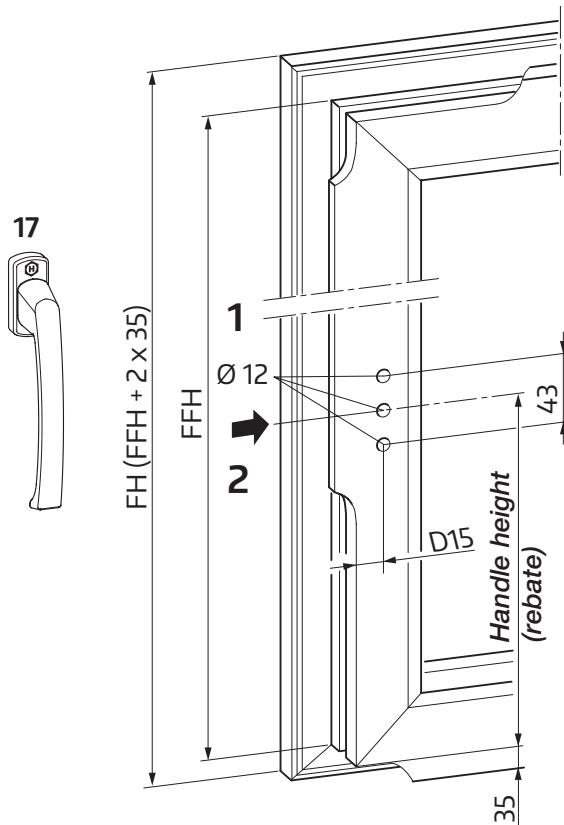

Detail D = 15

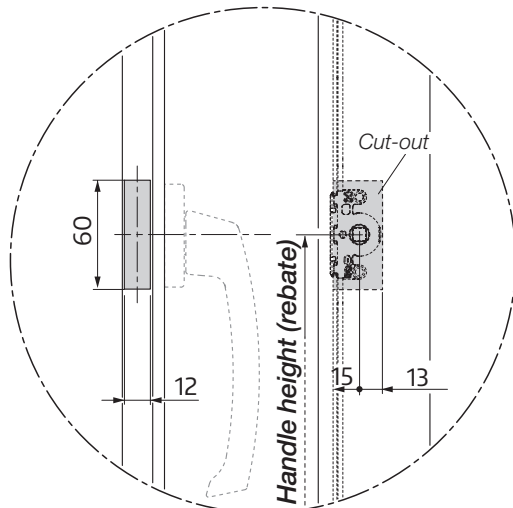

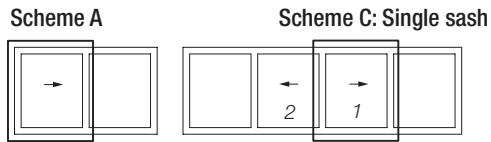

## Guide/bogie drill holes for Scheme A/Scheme C: Single-sash

- (1) Drill holes  $\varnothing 3.2$  for fastening the guides at top (1 and 2) using drilling template. Only drill through PVC if you use self-tapping screws.
- (2) Drill holes  $\varnothing 3.2$  for fastening the bogies (10) using drilling template. Only drill through PVC if you use self-tapping screws.

● Drill  
○ Not drill

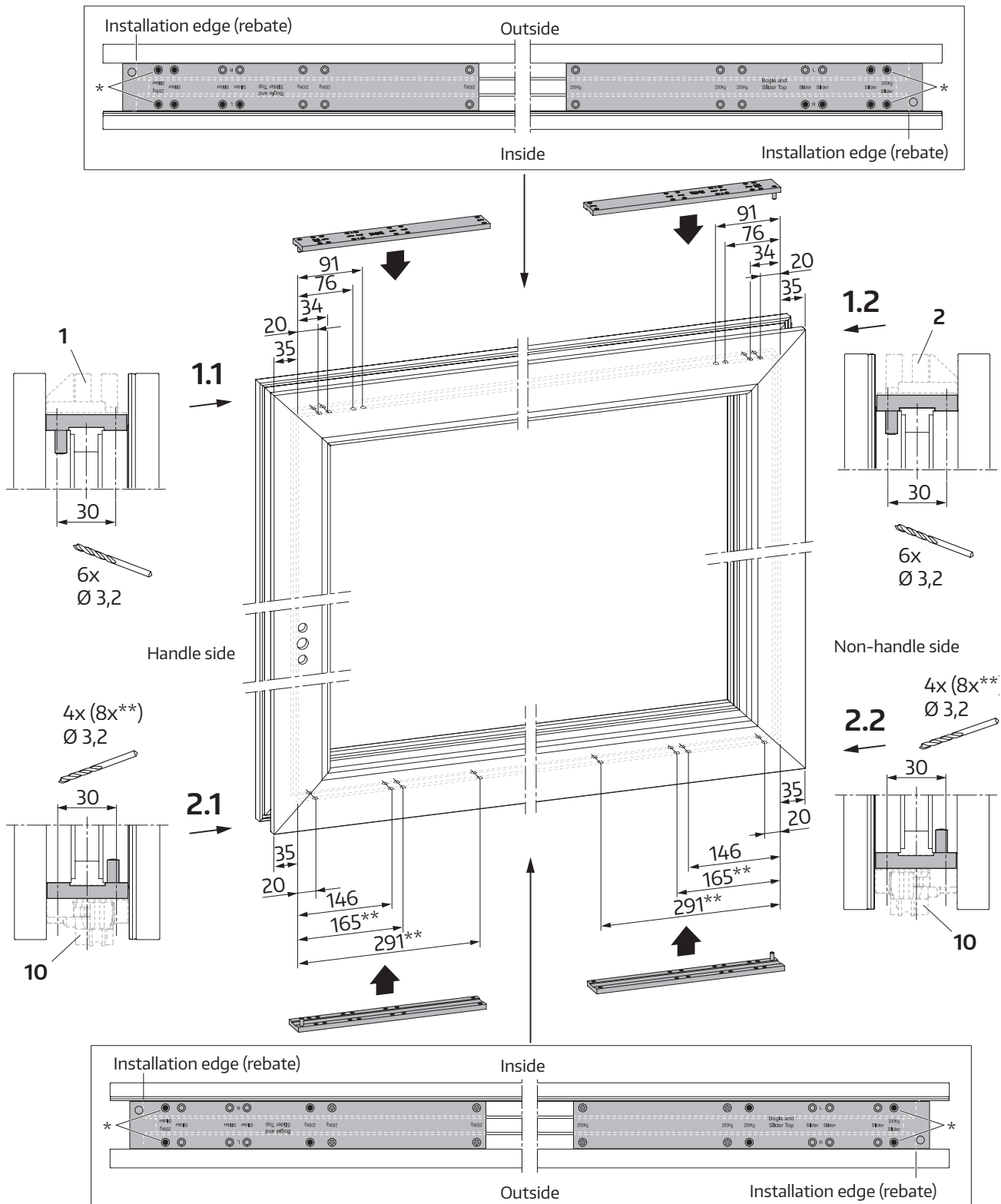

\*) Only pre-drill if steel reinforcement extends into the corner section  
\*\*) For SW > 200 kg only

Scheme C: Double sash

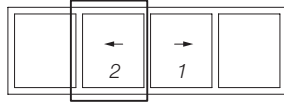

## Guide/bogie drill holes for Scheme C: Double sash

- (1) Handle side: drill holes  $\varnothing 3.2$  for fastening the guide on handle-side guide top (1) using drilling template. Only drill through PVC if you use self-tapping screws.
- (2) Handle side: drill holes  $\varnothing 3.2$  for fastening the bogie on handle side (10) using drilling template. Only drill through PVC if you use self-tapping screws.
- (3) Non-handle side: drill holes  $\varnothing 3.2$  for fastening the guide on non-handle side guide top (2) using drilling template. Only drill through PVC if you use self-tapping screws.
- (4) Non-handle side: drill holes  $\varnothing 3.2$  for fastening the bogie on non-handle side (10) using drilling template. Only drill through PVC if you use self-tapping screws.

● Drill      ○ Not drill

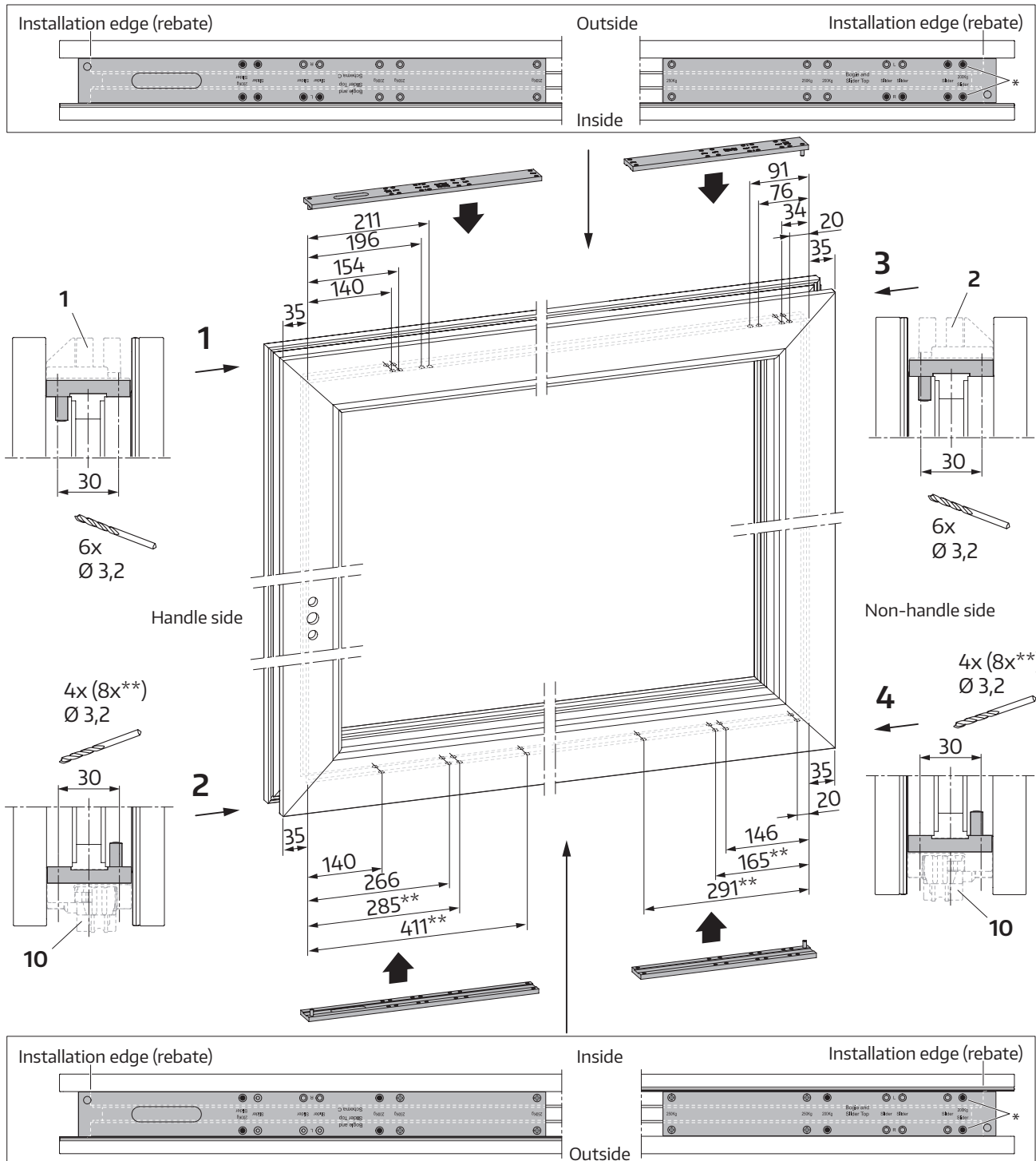

\*) Only pre-drill if steel reinforcement extends into the corner section  
 \*\*) For SW > 200 kg only

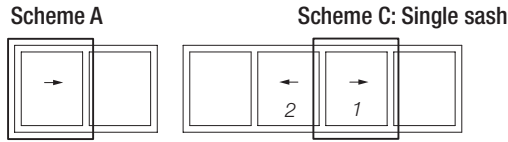

## Mounting on the sash

### Cutting rails to length, installing central locking gear MULTI-MATIC Scheme A/Scheme C single sash

- (1) Screw top and lower flexible corners (13) into place.
- (2) SRW > 1400 mm: screw width rod (15) extensions onto flexible corners on non-handle side.
- (3) Cut top and lower connecting rails (14) to length, punch and screw in place.
- (4) SRH > 1400 mm: Screw height rod (15) extension onto top flexible corner on non-handle side; SRH > 2110 mm: also screw height rod (15) extension onto lower flexible corner. SRH > 2400 mm: Screw espag (15) extension onto flexible corner on handle side.
- (5) Trim side connection rail (16) and espag rail (12), punch and screw into place.
- (6) For short espags without screw holes only: screw espag hold-down device (26) onto sash as shown.

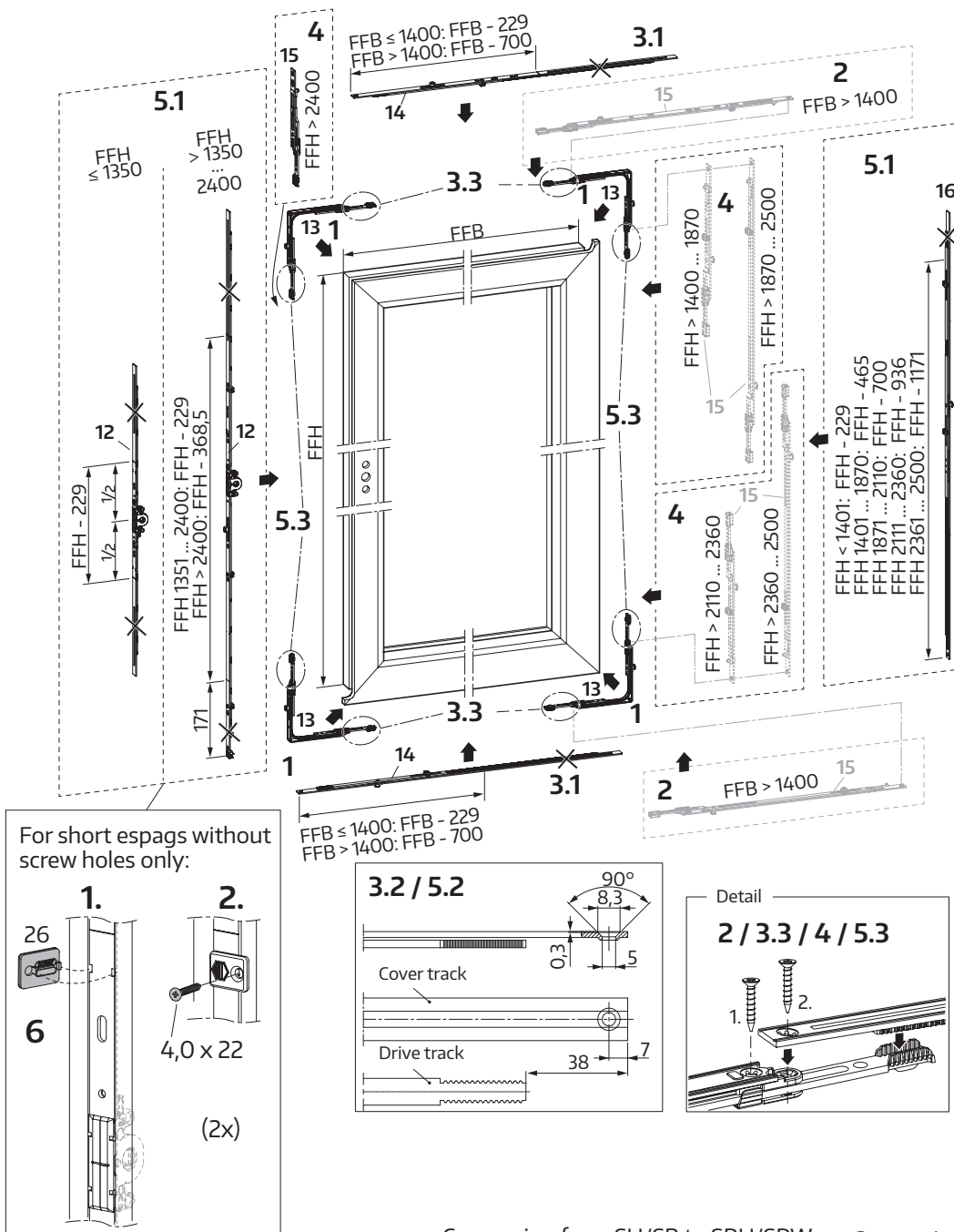

Conversion from SH/SB to SRH/SRW

$$\begin{aligned} \text{SRH} &= \text{SH} - 70 \\ \text{SRW} &= \text{SB} - 70 \end{aligned}$$

Conversion from SRH/SRW to SH/SB

$$\begin{aligned} \text{SH} &= \text{SRH} + 70 \\ \text{SB} &= \text{SRW} + 70 \end{aligned}$$

Scheme C: Double sash

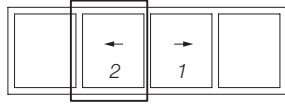

# Cutting rails to length, installing central locking gear MULTI-MATIC Scheme C double sash

- (1) Screw top and lower flexible corners (13) into place.
- (2) SRW > 1400 mm: screw width rod (15) extensions onto flexible corners on non-handle side.
- (3) Cut top and lower connecting rails (14) to length, punch and screw in place. IMPORTANT: if SRW ≤ 900 mm, the connection rail **must** be installed with the trimmed section facing the handle side.
- (4) SRH > 1400 mm: Screw height rod (15) extension onto top flexible corner on non-handle side; SRH > 2110 mm: also screw height rod (15) extension onto lower flexible corner. SRH > 2400 mm: Screw espag (15) extension onto flexible corner on handle side.
- (5) Trim side connection rail (16) and espag rail (12), punch and screw into place.
- (6) For short espags without screw holes only: screw espag hold-down device (26) onto sash as shown.

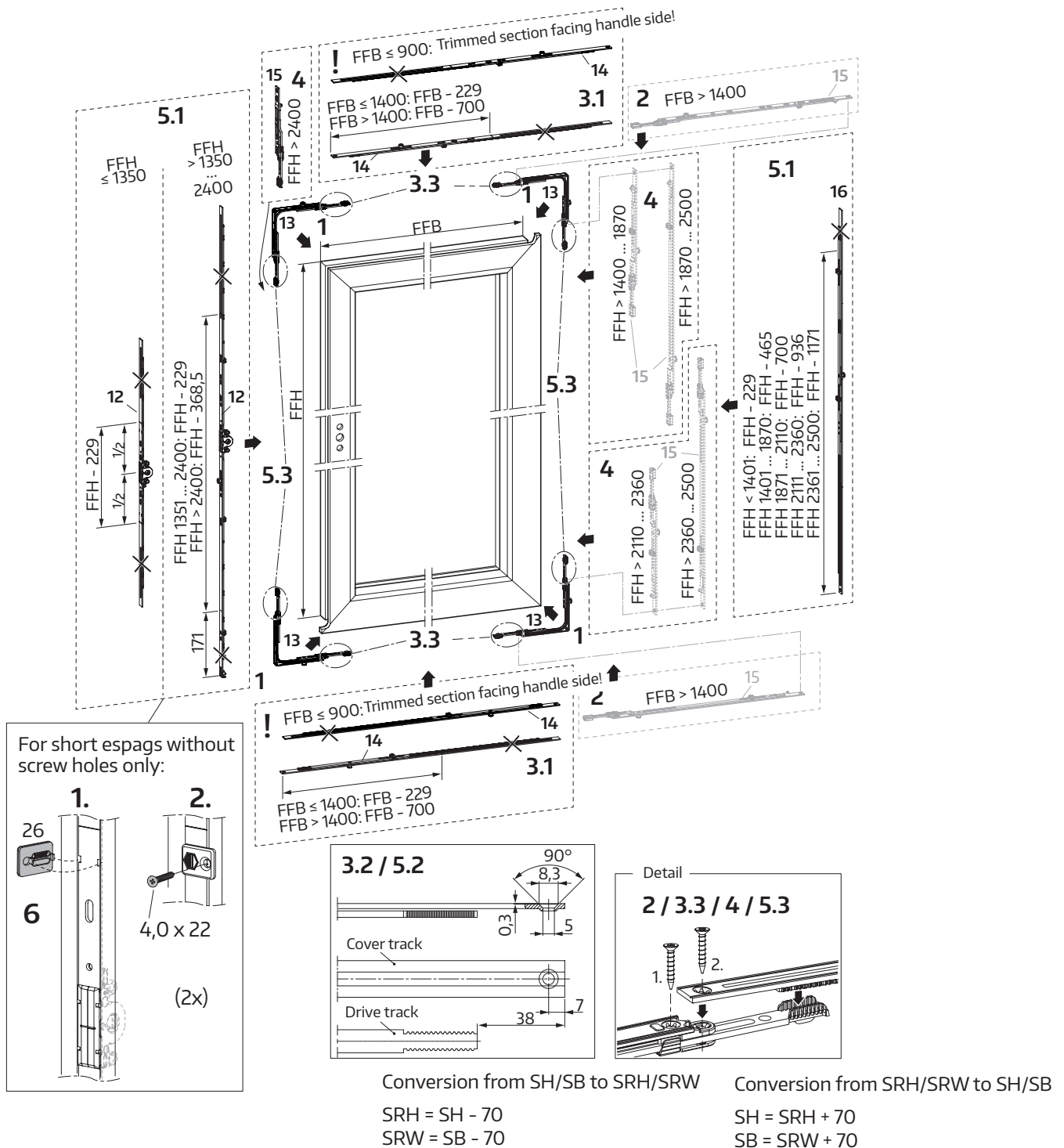



# Installing handle, top/lower locking devices, bogies, guides

- (1) Place central locking gear on the espag in centre position and fit handle 161 EG or 161 EG-S in centre.
- (2) Place drilling template for locking devices top/lower/MST on the corresponding width rod locking pin (see following page) at top and bottom and drill the required holes. <sup>1)</sup> Only drill through PVC if you use self-tapping screws (1). Remove drilling template (2). Align TOP (3)/BOTTOM (11) correctly (see arrow and inscription INSIDE) and fasten to sash (3) with 4 screws 4.0 x 22 each (alternatively, self-tapping screws 3.9 x 25).
- (3) Place drilling template on the locking pins on the height rod (16), the extensions (15) and the flexible corners (13/13a) on the non-handle side (see section on Positioning drilling template for locking devices MST on the non-handle side) and drill the required holes. <sup>1)</sup> Only drill through PVC if you use self-tapping screws (1) (here: also 2 holes Ø 12 for locking parts MST (2); see section on Locking parts MST). Remove drilling template (3). Align MST locking devices (7) correctly (see arrow and inscription INSIDE) and fasten to sash (4) with 4 screws 4.0 x 22 each (alternatively, self-tapping screws 3.9 x 25).
- (4) Align bogie (10) correctly (see arrow and inscription INSIDE) and fasten onto the sash (with 4 screws 4.0 x 22 per bogie; alternatively, self-tapping screws 3.9 x 25).
- (5) Oil running surfaces on guides (1 and 2). Align guides correctly (see arrow and inscription INSIDE) and fasten at the designated points (4) with 4 screws 4.0 x 22 each (alternatively, self-tapping screws 3.9 x 25).

**⚠ Warning: do not overwind screws (1.5– 2 Nm). Window sash is not adequately secured otherwise. This can lead to severe physical injury.**

- <sup>1)</sup> Only drill holes for screws if the steel reinforcement is located in this section. Holes for centring must always be drilled (through the PVC is sufficient).
- <sup>2)</sup> Number of locking points depends on SRW; see following page for locking overview with marks for the required locking pins
- <sup>3)</sup> Number of locking points depends on SRH; see section on Positioning drilling template for locking devices MST on the non-handle side for marks for the required locking pins.
- <sup>4)</sup> For SW > 200 kg only

Depends on the version; the diagram for holes may differ.

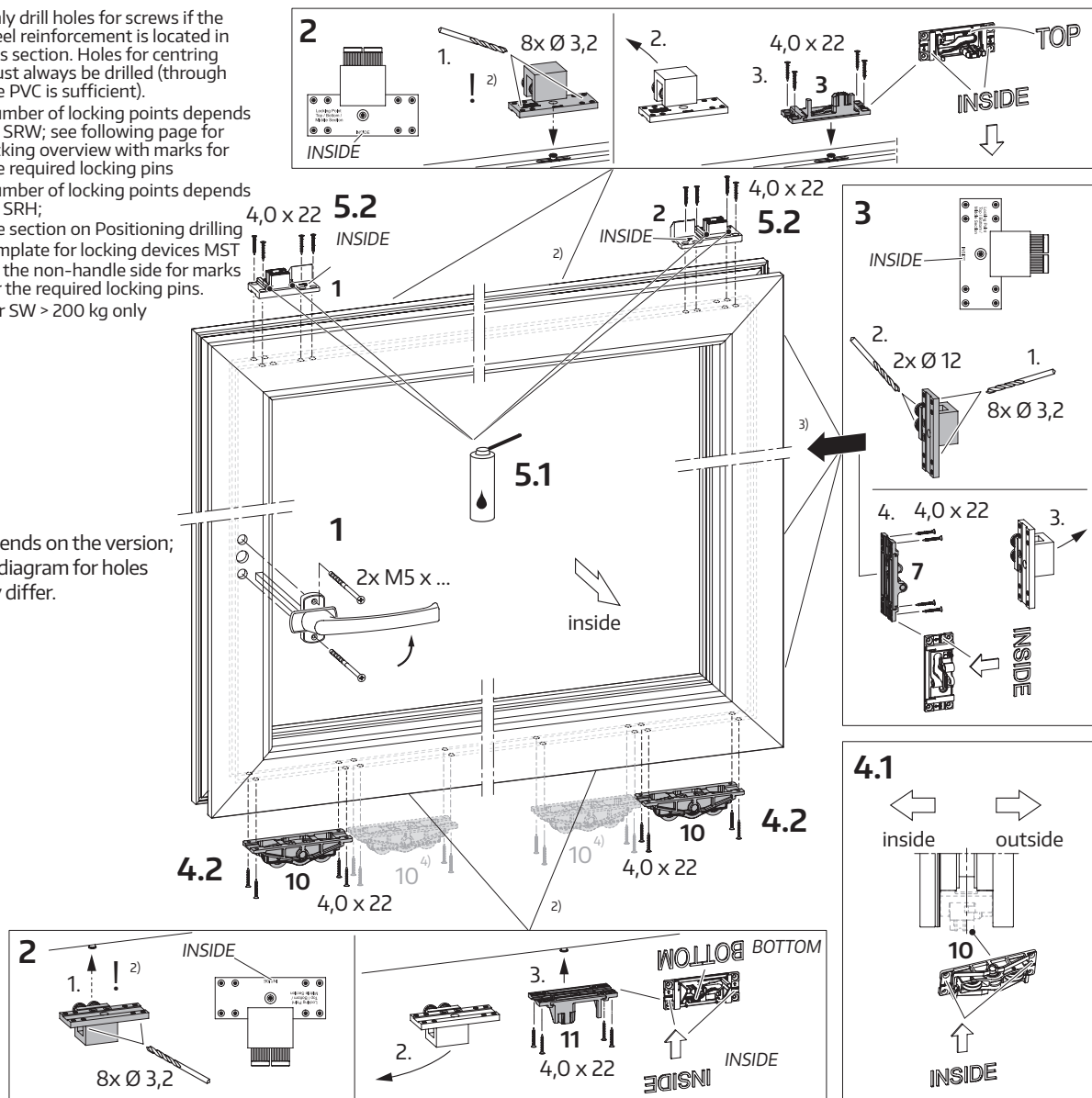

Scheme A

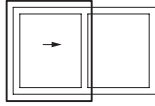

Scheme C: Single sash

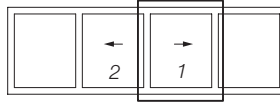

# Positioning drilling template for top/lower locking devices

Scheme A/Scheme C  
single sash

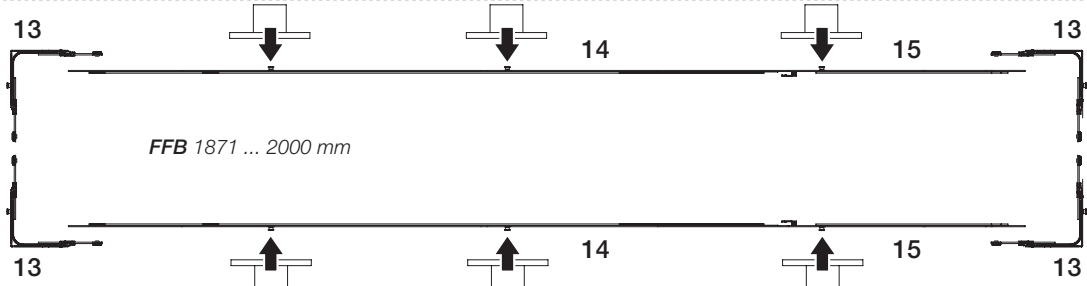
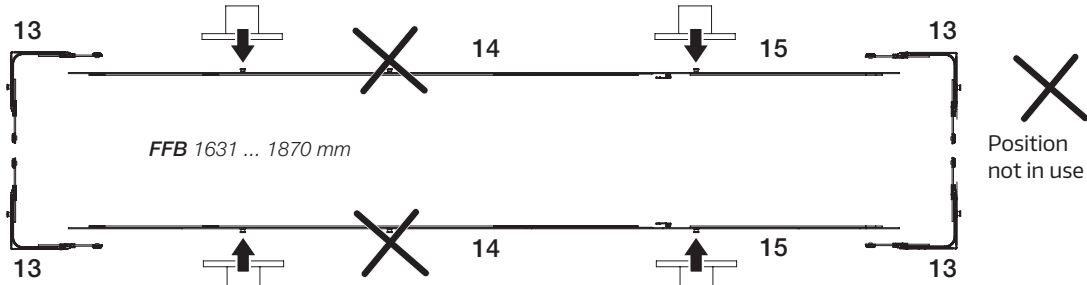
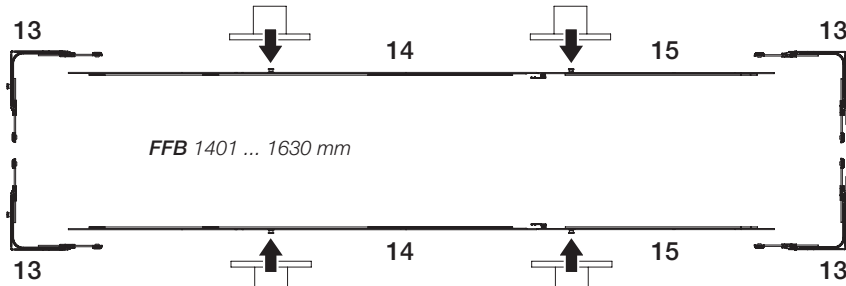
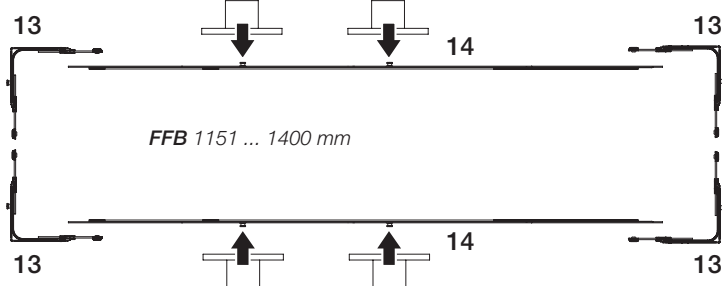
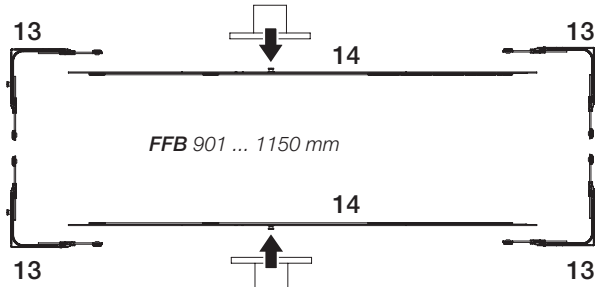
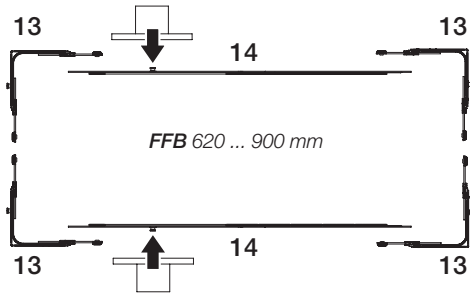

Handle side

Non-handle side

Scheme C: Double sash

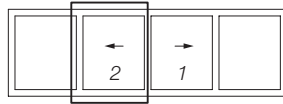

Positioning drilling template for top/lower locking devices

Scheme C single sash

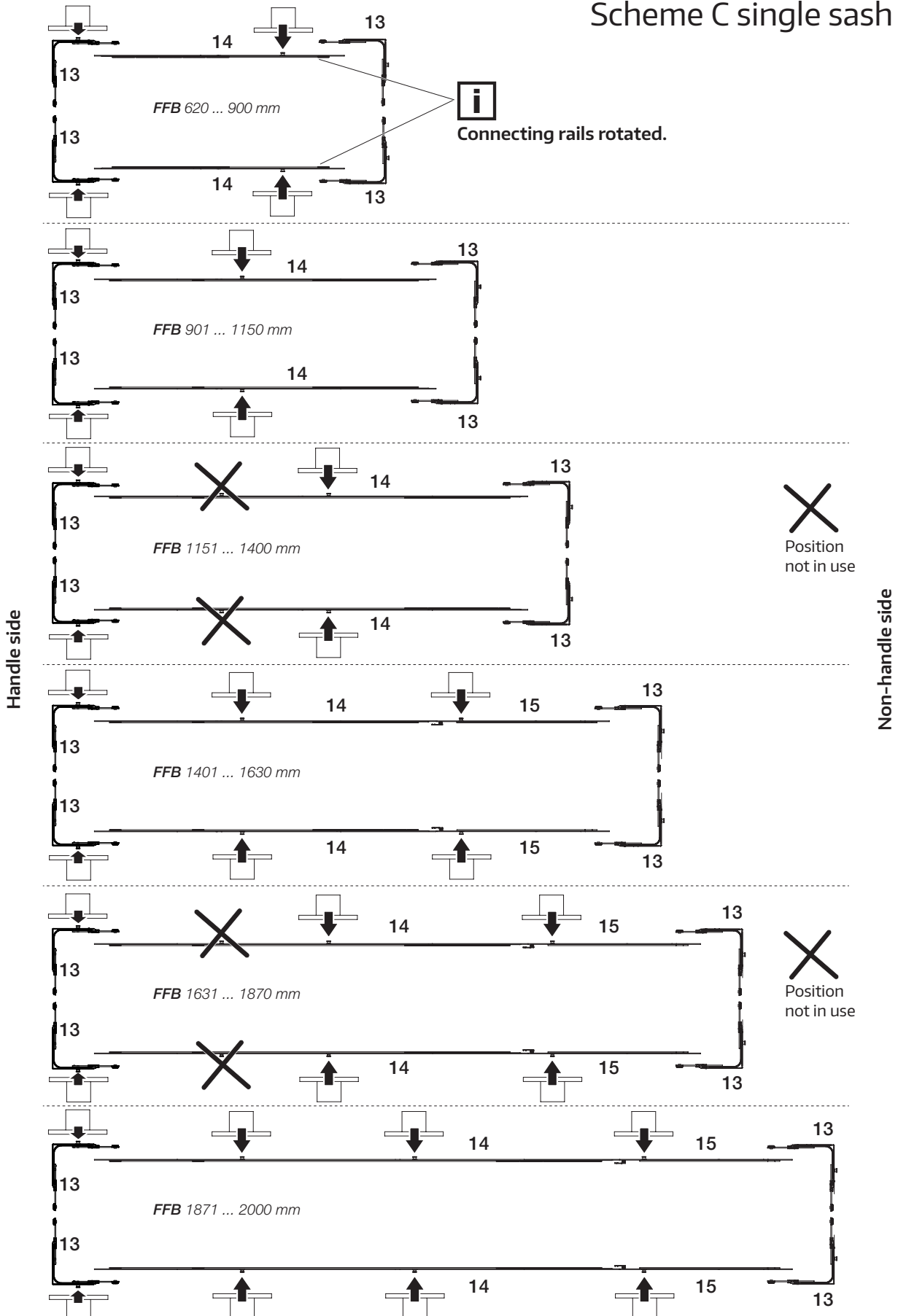

Scheme A

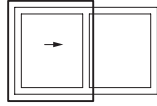

Scheme C: Single and double sash

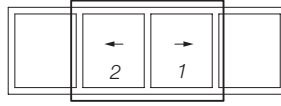

# Positioning drilling template for top/lower locking devices on the non-handle side

## Scheme A/Scheme C single and double sash

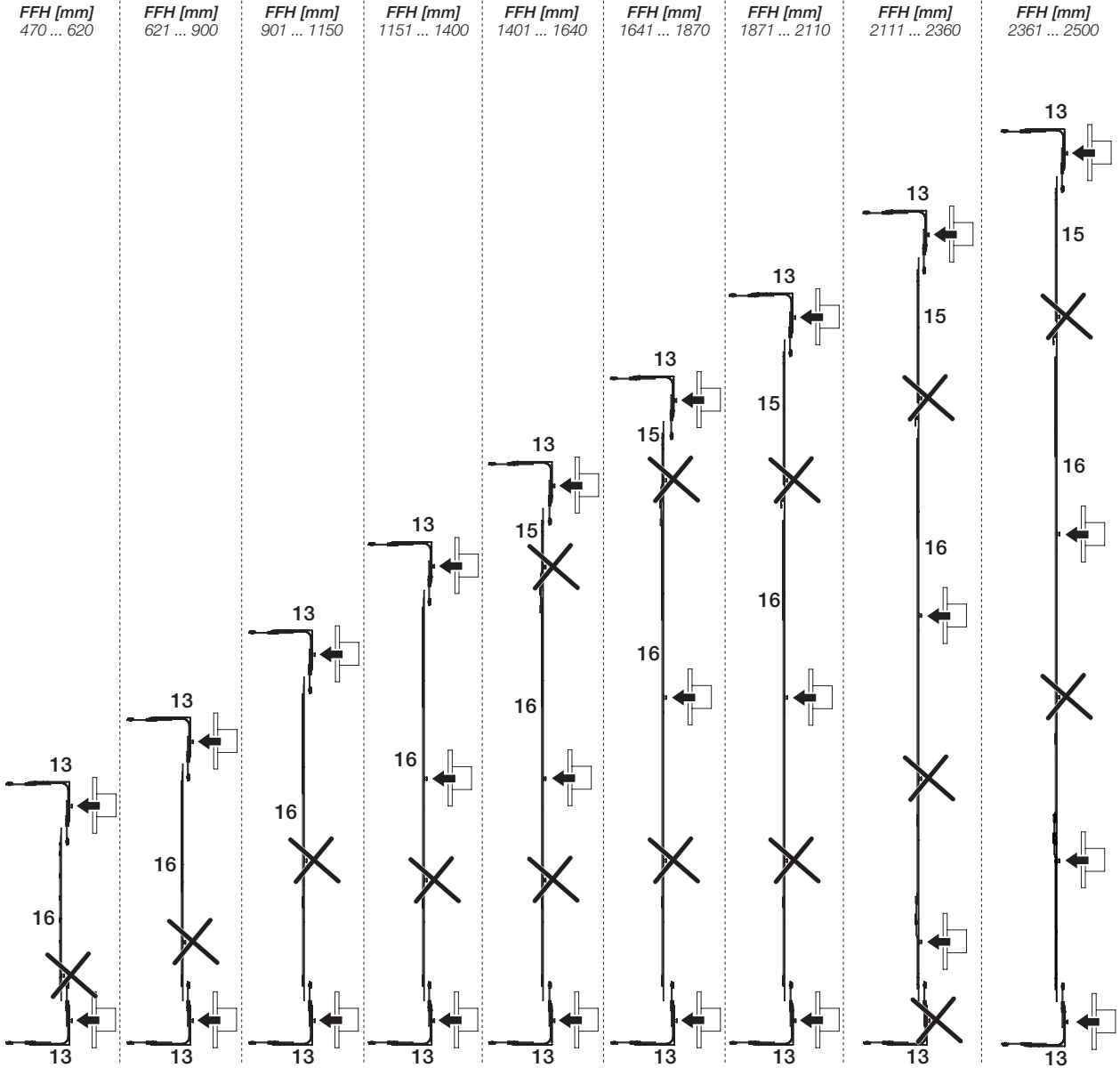
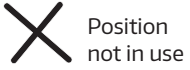

## Mounting locking parts MST

- (1) Place handle in locked position.
- (2) Insert locking parts MST (6) as shown through the drilled holes.
- (3) Screw the adjustment bolts for the locking parts MST (6) into the locking devices MST (7) by applying  T 25 until they rest on the template as shown (basic setting of the locking device).

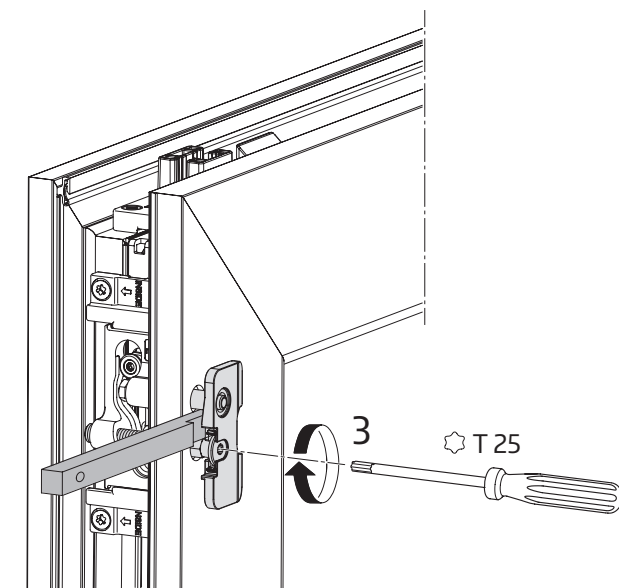
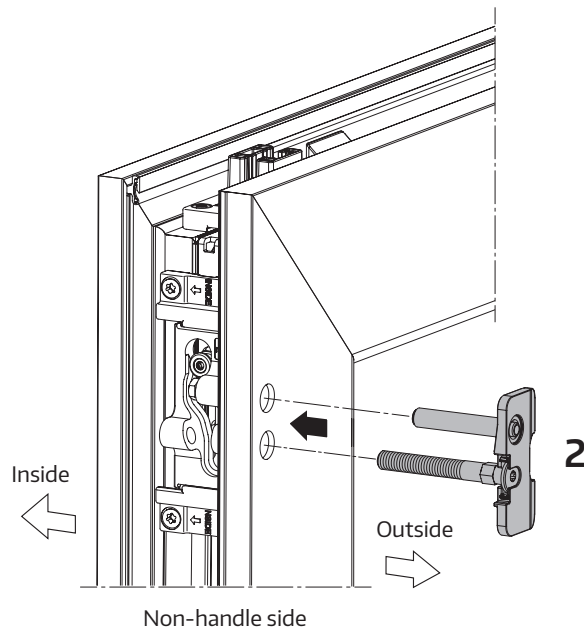
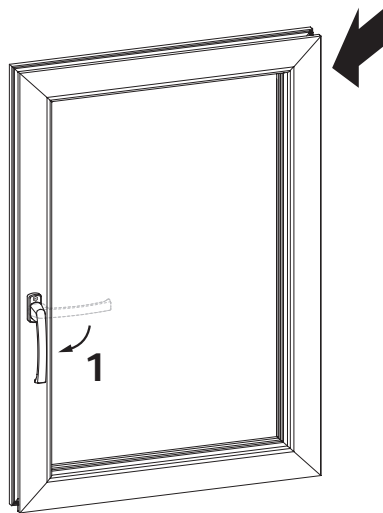

Scheme A

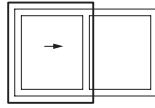

## Cutting additional profiles to length/installing, Scheme A

- (1) Frame profile <sup>1)</sup>:  $L_1 = \text{FPH} - 80 \text{ mm}$ , cut to length and screw in place\*.
- (2) Running track <sup>1)</sup>:  $L_2 = \text{FPW} - 105.5 \text{ mm}$ , cut to length and screw in place\*.
- (3) Guide track <sup>1)</sup>:  $L_3 = \text{FPW} - 105.5 \text{ mm}$ , cut to length;

**The guide track is not screwed onto the frame until the sliding sash is installed; otherwise, the sliding sash cannot be inserted into the frame.**

\*) Use:

 Pre-drill  $\varnothing 3.2$   
4,0 x 22

Alternatively:  
Self-tapping screw 3.9 x 25

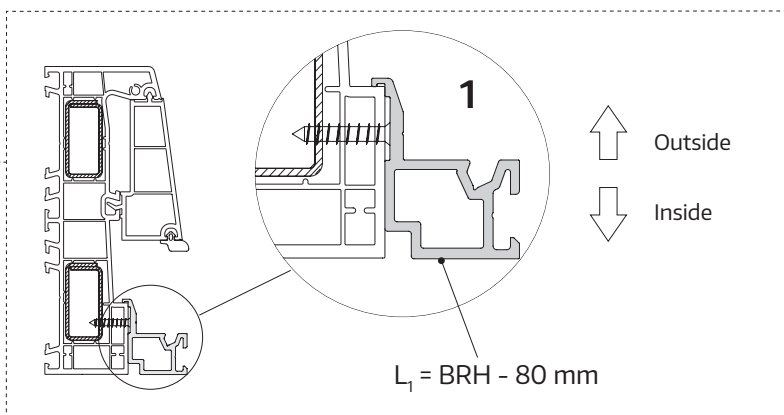
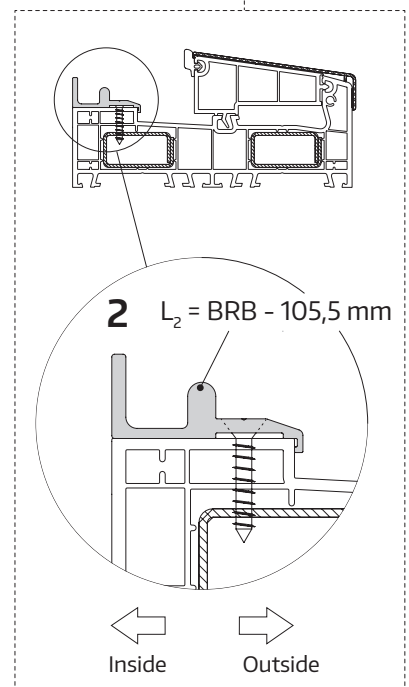
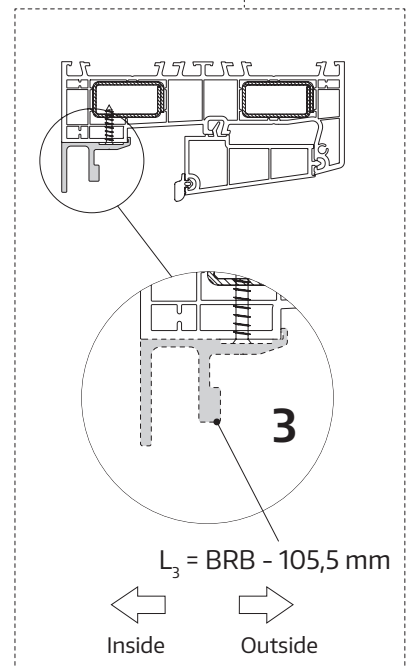
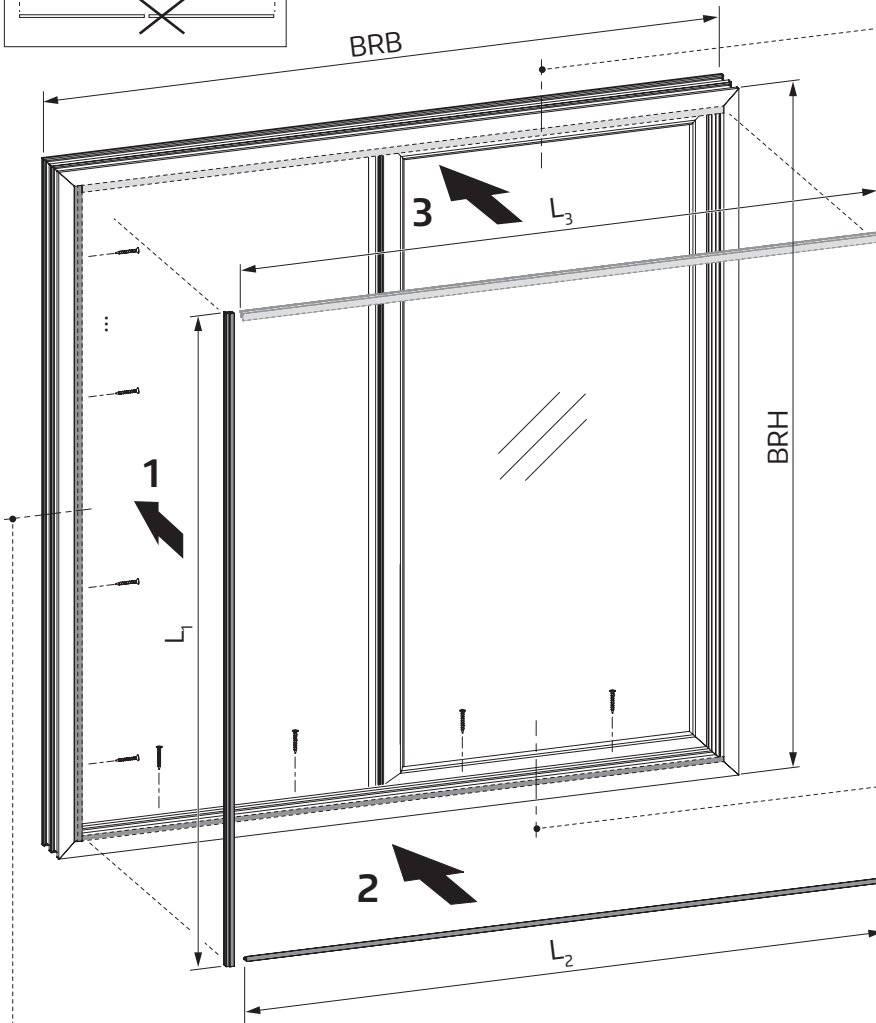
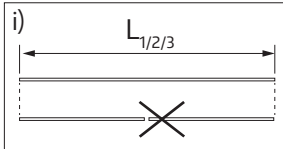

Scheme C

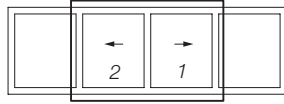

## Cutting additional profiles to length/installing, Scheme C

- (1) Mullion profile <sup>1)</sup>:  $L_1 =$  cut SRH to length and screw onto double/fixed sash\*.
- (2) Running track <sup>1)</sup>:  $L_2 =$  FPW - 80 mm, cut to length and screw in place\*\*. Seal running track with silicone along its whole length.
- (3) Guide track <sup>1)</sup>:  $L_3 =$  (FPW - 80) / cut off 2 mm (length on each side); **The guide track is not screwed onto the frame until the sliding sash is installed; otherwise, the sliding sash cannot be inserted into the frame.**

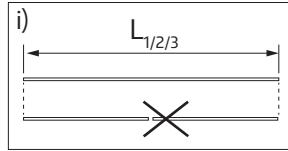

Double sash (fixed sash)

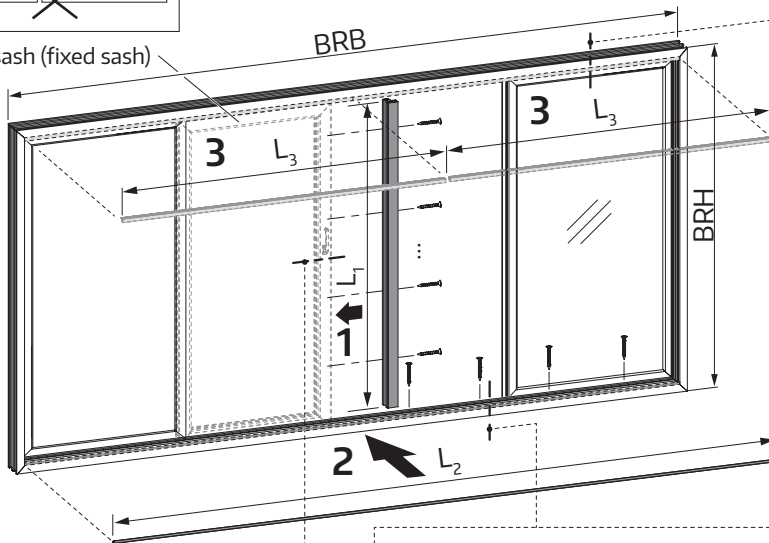

\*) Use screws as per system manufacturer's specifications

\*\*\*) Use:

Pre-drill  $\varnothing 3.2$   
4,0 x 22

Alternatively:  
Self-tapping screw 3.9 x 25

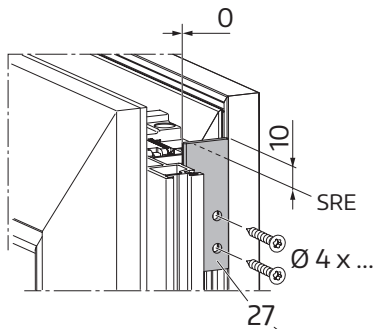
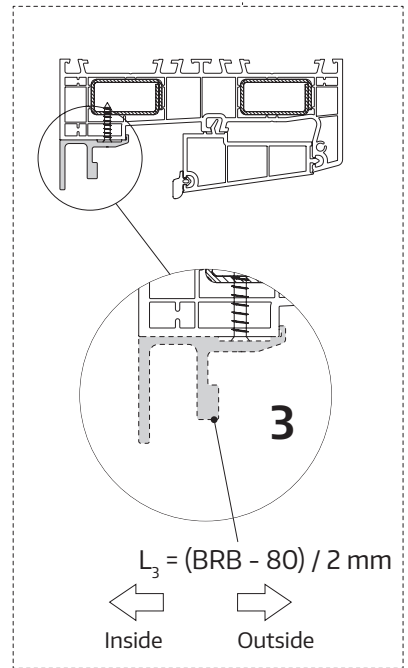

Cross-section with active and fixed sashes

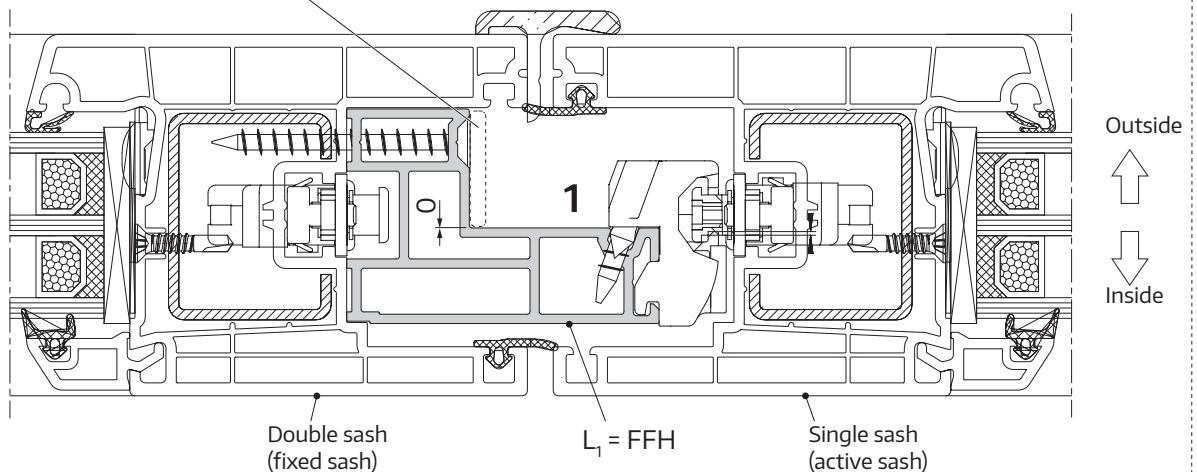
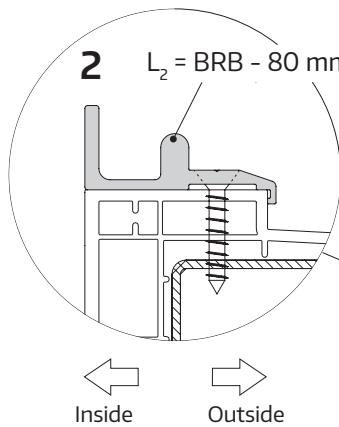

Scheme A

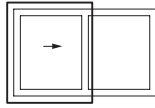

## Installing strikers on handle side and strikers MST for Scheme A

- (1) Press the rubber frame buffers into the strikers on the handle side (4)\* and pre-position them as shown and slightly tighten each one to a threaded pin using  $\odot$  T 10. Once the sliding sash has been fitted, the strikers on the handle side can be positioned using a drilling template (see section on Correcting the position of strikers on handle side).
- (2) Mount strikers MST (8) with side alignment to the central stile profile strip as shown using 3 screws 4.8 x 28 on each (alternatively, self-tapping screws 4.8 x 32). If necessary, use filling piece to measure more effectively in the running track section.

\*) If needed, use tool to fit the rubber frame buffer more easily (e.g. cotter pin drive)

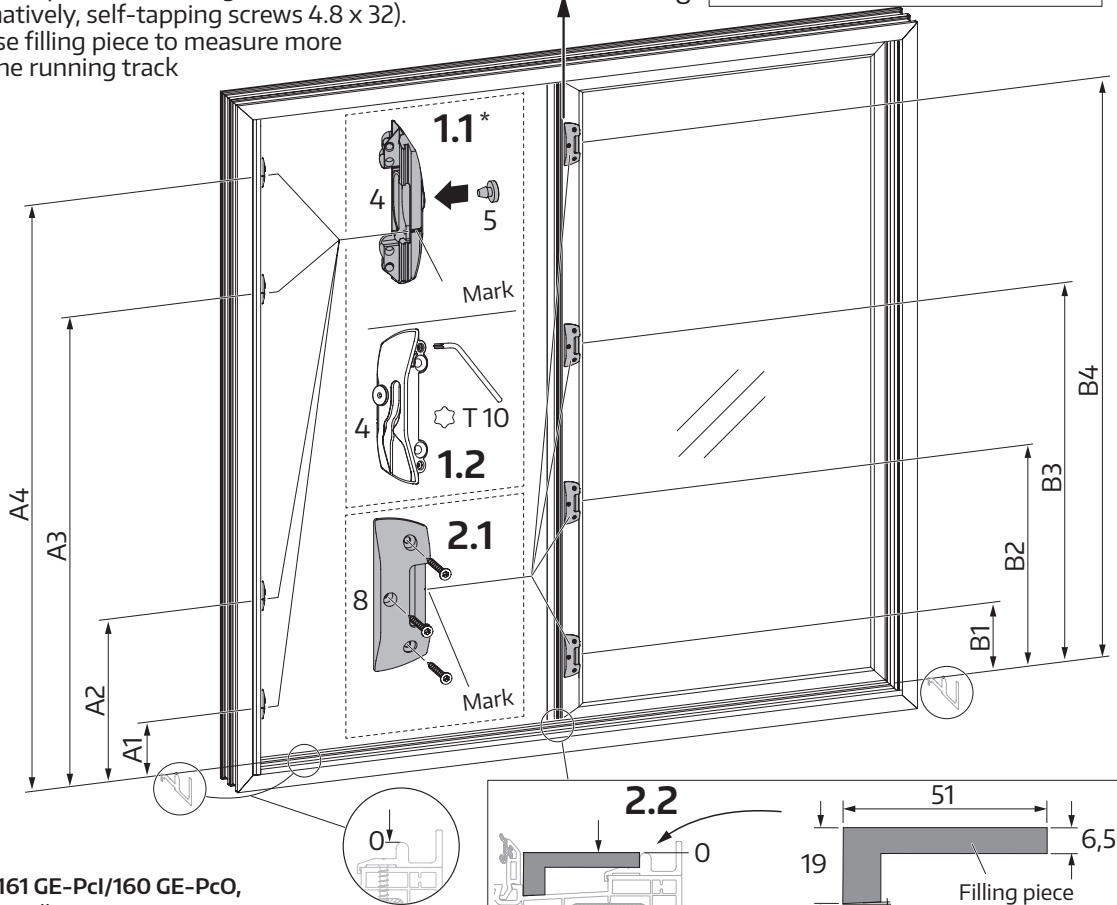
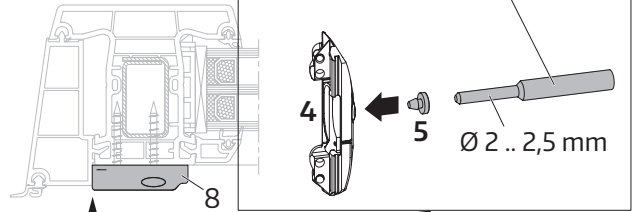

In the case of handle 161 GE-Pcl/160 GE-PcO, see section Installing handle 161 GE-Pcl/160 GE-PcO

SRH	(for pre-positioning)			
	A1	A2	A3	A4
470- 800	100	-	-	SRH - 40
801- 900	100	-	-	SRH - 40
901- 1250	100	SRH/2 + 124.5	-	SRH - 40
1251- 1350	100	SRH/2 + 124.5	-	SRH - 40
1351- 1540	100	849	-	SRH - 40
1541- 1650	100	949	-	SRH - 40
1651- 1700	100	724	-	SRH - 40
1701- 1900	100	724	1394	SRH - 40
1901- 2150	100	724	1394	SRH - 40
2151- 2400	100	724	1394	SRH - 40
2401- 2500	100	724	1394	SRH - 40

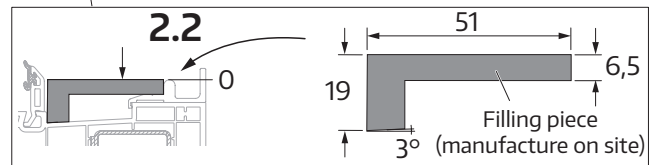

SRH	B1	B2	B3	B4
470- 620	93	-	-	SRH - 47
621- 900	93	-	-	SRH - 47
901- 1150	93	-	-	SRH - 47
1151- 1400	93	-	776.5	SRH - 47
1401- 1640	93	-	776.5	SRH - 47
1641- 1870	93	-	1010.5	SRH - 47
1871- 2110	93	-	1010.5	SRH - 47
2111- 2360	306.5	-	1246.5	SRH - 47
2361- 2500	93	541.5	1481.5	SRH - 47



Scheme C

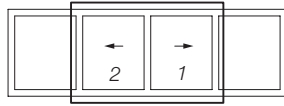

## Installing strikers on handle side and strikers MST for Scheme C

- (1) Press the rubber frame buffers into the strikers on the handle side (4)\* and pre-position them as shown and slightly tighten each one to a threaded pin using T 10. Once the sliding sash has been fitted, the strikers on the handle side can be positioned using a drilling template (see section on Correcting the position of strikers on handle side).
- (2) Mount strikers MST (8) with side alignment to the profile strips on the inner side of the fixed sash as shown using 3 screws 4.8 x 28 on each (alternatively, self-tapping screws 4.8 x 32). If necessary, use filling piece to measure more effectively in the running track section.

\*) If needed, use tool to fit the rubber frame buffer more easily (e.g. cotter pin drive)

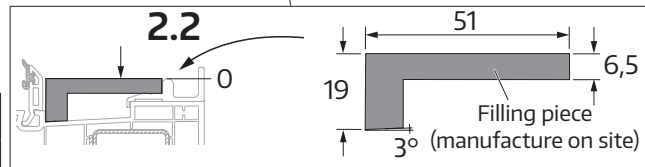
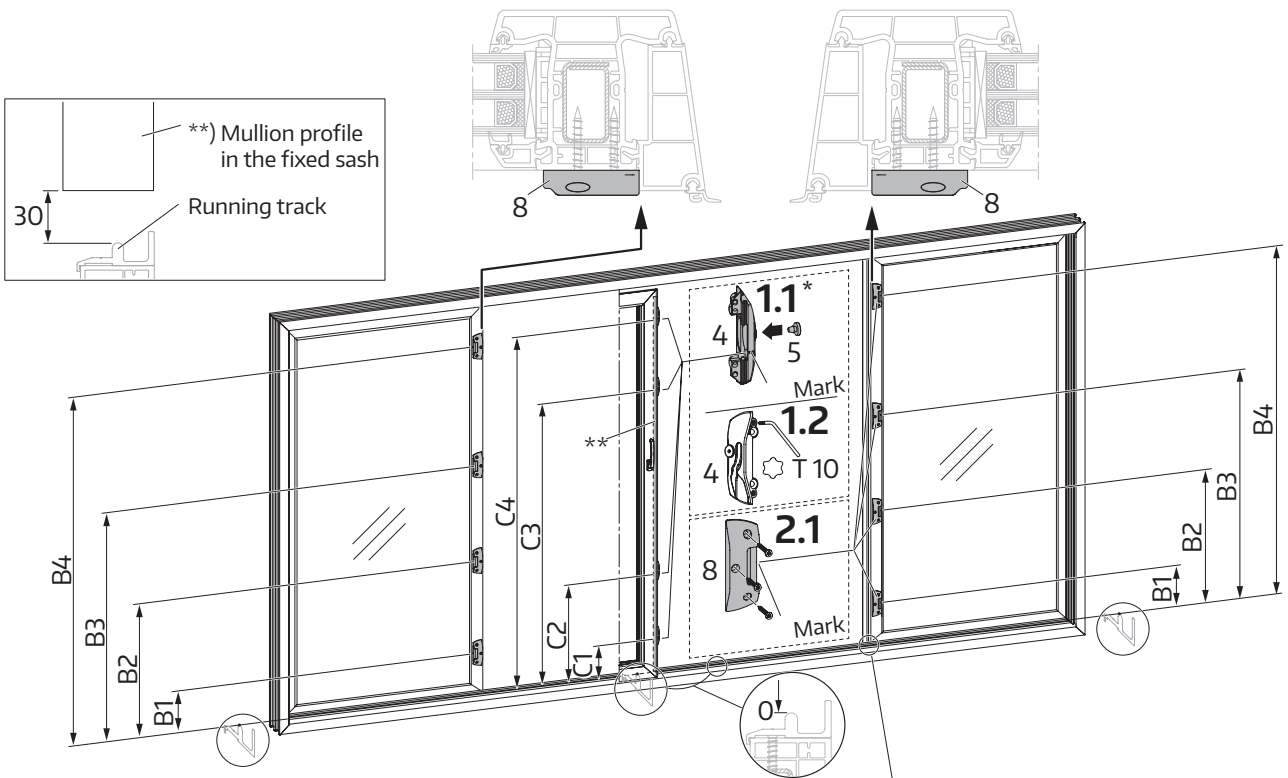
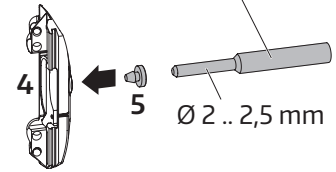

SRH	(for pre-positioning)			
	C1	C2	C3	C4
470- 800	100	-	-	SRH - 40
801- 900	100	-	-	SRH - 40
901- 1250	100	SRH/2 + 124.5	-	SRH - 40
1251- 1350	100	SRH/2 + 124.5	-	SRH - 40
1351- 1540	100	849	-	SRH - 40
1541- 1650	100	949	-	SRH - 40
1651- 1700	100	724	-	SRH - 40
1701- 1900	100	724	1394	SRH - 40
1901- 2150	100	724	1394	SRH - 40
2151- 2400	100	724	1394	SRH - 40
2401- 2500	100	724	1394	SRH - 40

SRH	B1	B2	B3	B4
470- 620	93	-	-	SRH - 47
621- 900	93	-	-	SRH - 47
901- 1150	93	-	-	SRH - 47
1151- 1400	93	-	776.5	SRH - 47
1401- 1640	93	-	776.5	SRH - 47
1641- 1870	93	-	1010.5	SRH - 47
1871- 2110	93	-	1010.5	SRH - 47
2111- 2360	306.5	-	1246.5	SRH - 47
2361- 2500	93	541.5	1481.5	SRH - 47

Scheme A

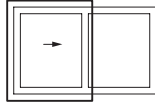

## Installing the sash for Scheme A

**Warning:** Do not carry out the following work steps alone. You need a second person to help; otherwise, you may cause material damage and physical injury.

- (1) Position handle (17/18) upwards.
- (2) Place bogies in parked position.
- (3) Place the sash on the running track in the walk-through space and pivot the sash with the guide track into the frame.
- (4) Fasten guide track to the frame using screws 4.0 x 22 (alternatively, self-tapping screws 3.9 x 25).  
To fix in the walk-through space, open the sliding sash completely and support the guide track while doing so (not shown).

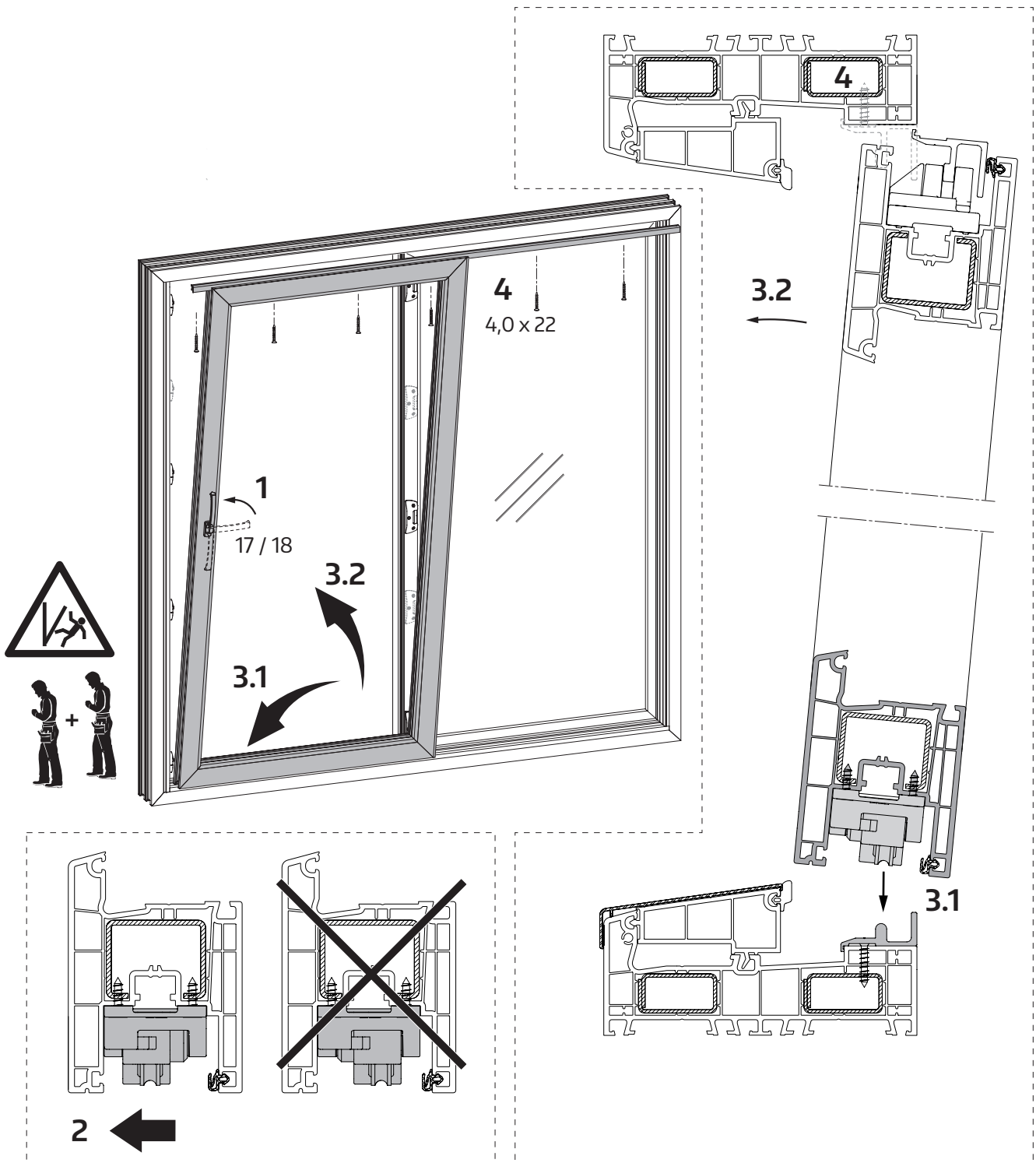

Scheme C

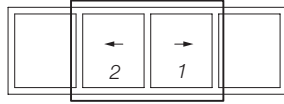

## Installing the sash for Scheme C

**Warning:** Do not carry out the following work steps alone. You need a second person to help; otherwise, you may cause material damage and physical injury.

### Install active sash (single sash):

- (1) Position handle (17/18) upwards.
- (2) Place bogies in parked position.
- (3) Push stopper onto the guide track as shown (see page 30 for final position). It **cannot** be placed into its final position until the fixed sash is installed.
- (4) Place the sash on the running track in the walk-through space and pivot the sash with the guide track into the frame.
- (5) Fasten guide track to the frame using screws 4.0 x 22 (alternatively, self-tapping screws 3.9 x 25). To fix in the walk-through space, open the sliding sash completely and support the guide track while doing so (not shown).

### Install fixed sash (double sash):

See active sash (single sash) for procedure

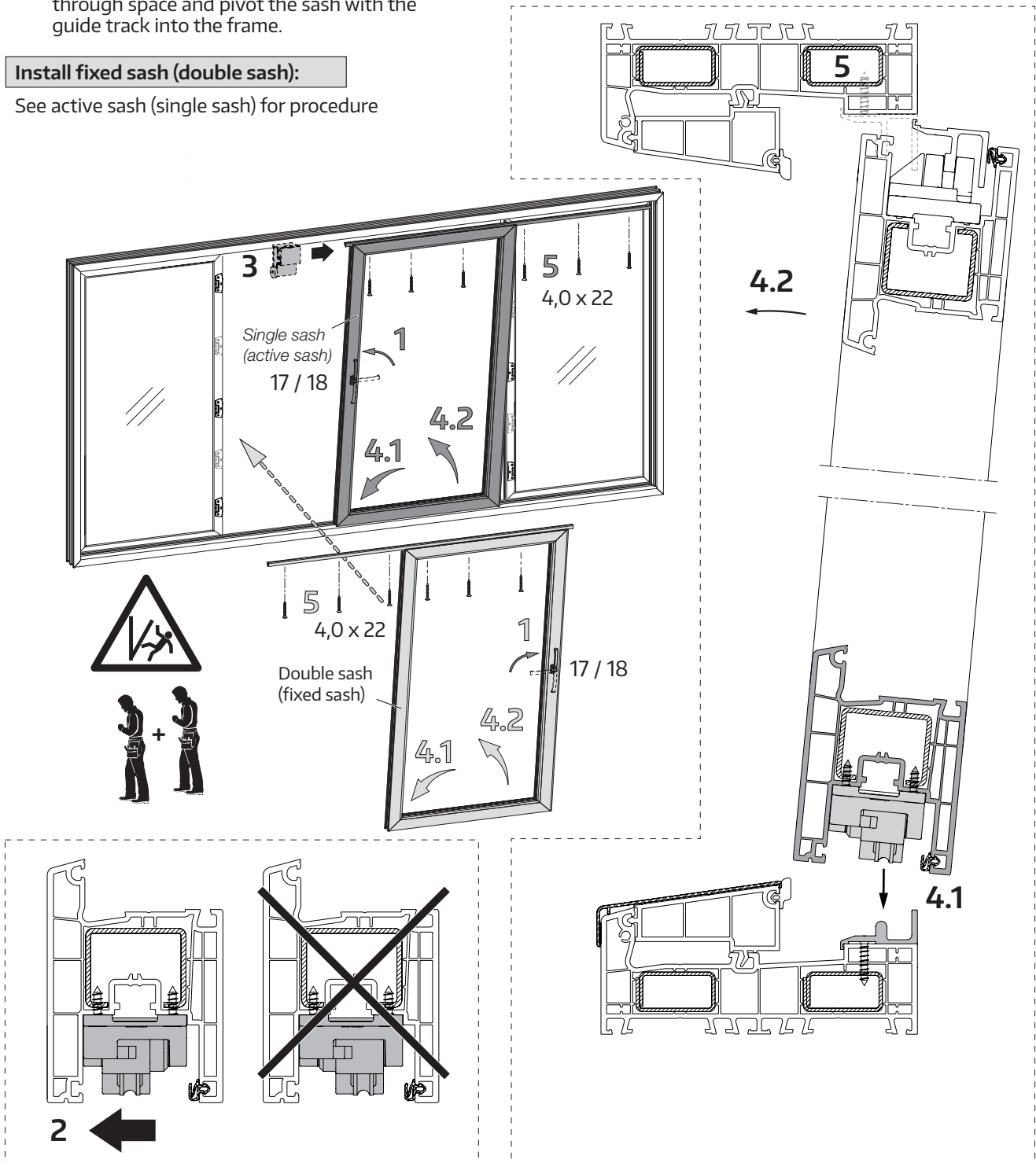

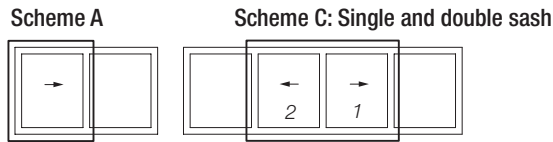

## Correcting the position of strikers on the handle side \*

(repeat procedure 2–5 one after another for all strikers on handle side)

- (1) Position handle upwards.
- (2) Place template on the gear locking pin as shown (see following page).
- (3) Scheme A: push the sash onto the frame until the template rests against it.  
Scheme C: push single sash (active sash) towards the closed double sash (fixed sash) until the template rests against it.
- (4) Check the position of the striker (4) in relation to the template and correct if necessary.
- (5) Fasten both threaded pins using  $\star$  T 10 (1.5– 2 Nm).

\*) For handle 161 GE-Pcl/160 GE-PcO:  
See separate section

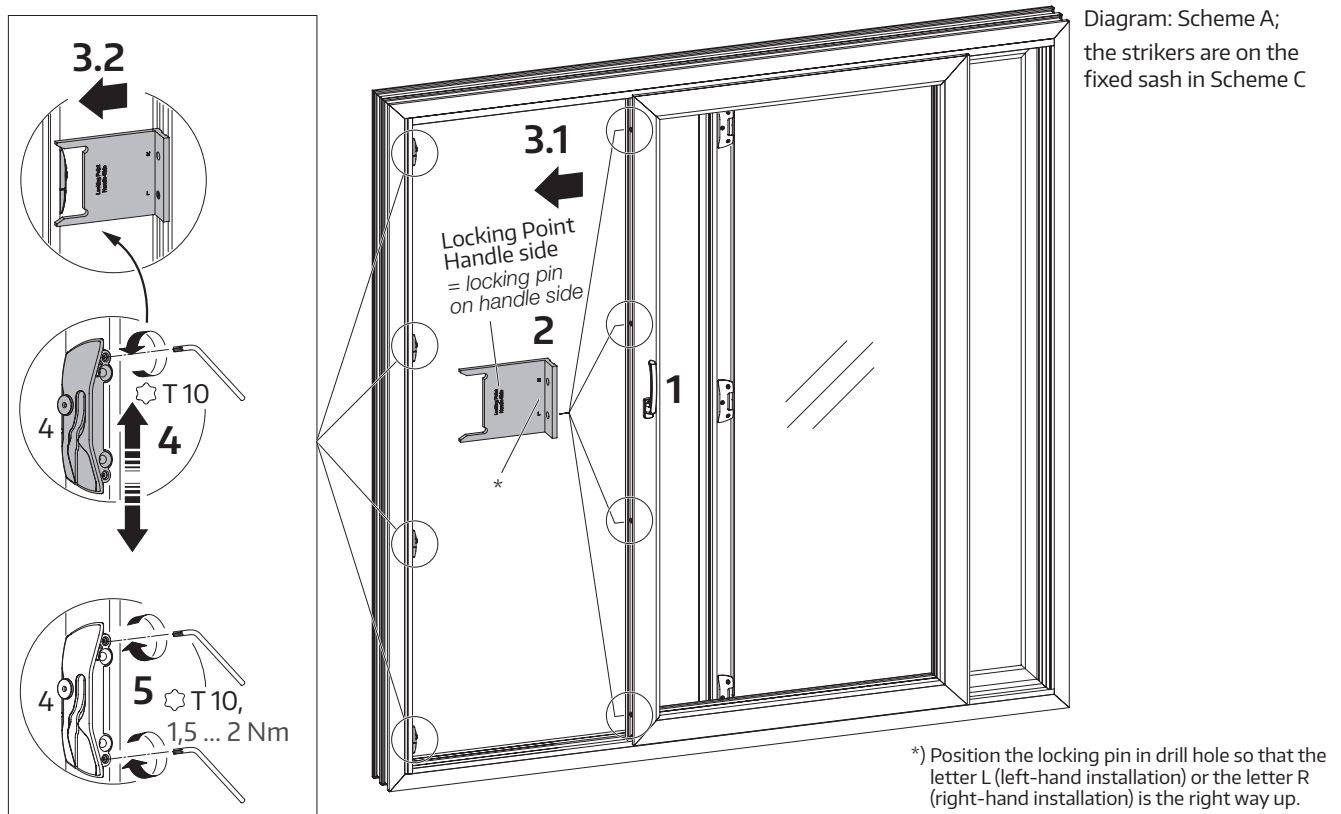

## checking that locking devices MST engage (for all strikers MST)

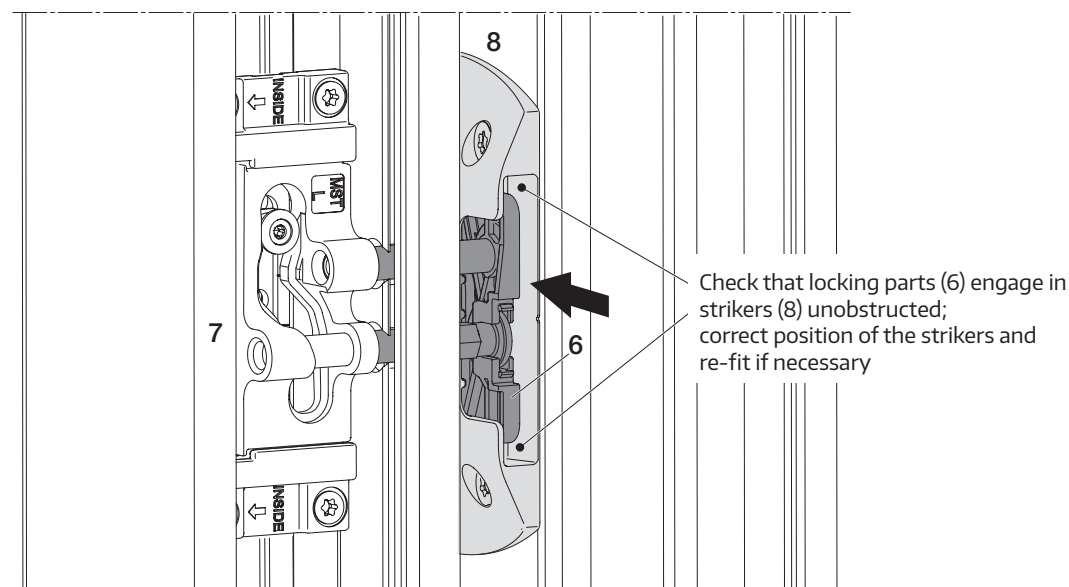

Scheme A

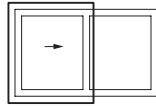

Scheme C: Single sash

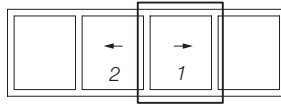

## Positioning the drilling template for strikers on the handle side

For handle 161 GE-Pcl/160 GE-PcO:  
See separate section



**Scheme C: Single sash**

i

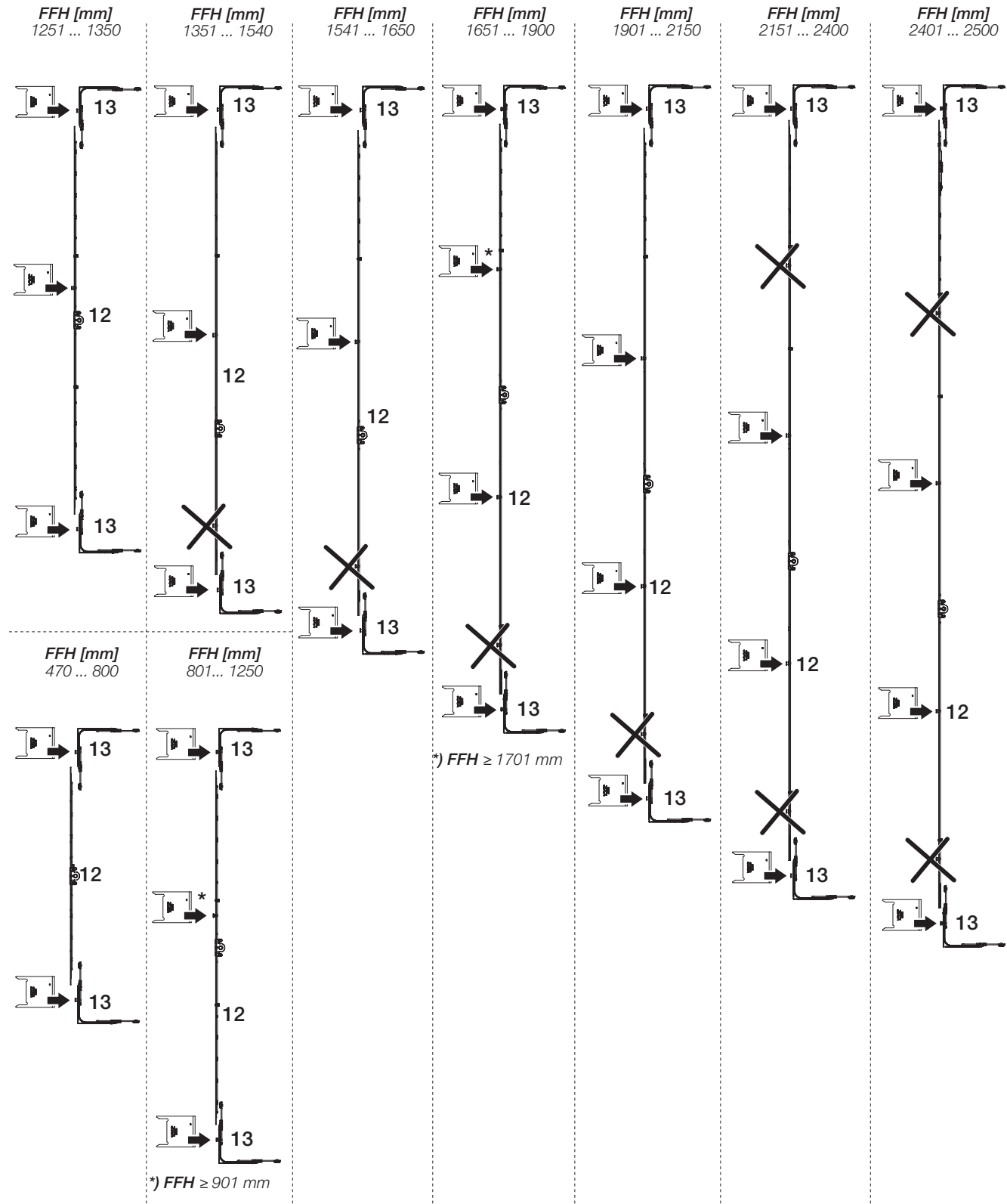

Scheme C

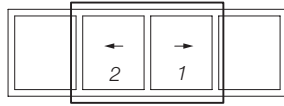

## Fitting top stopper for Scheme C

**Warning:** Do not carry out the following work steps alone. You need a second person to help; otherwise, you may cause material damage and physical injury.

Work steps (1), (2), (3), (5), (6) and (7) only need to be carried out if the top stopper on page 27 has not been pushed onto the guide track.

- (1) Position handle upwards.
- (2) Unscrew the guide track from the frame in the active sash section.
- (3) Take single sash (active sash) from the frame.
- (4) Mount the rubber frame buffer (5) in the top stopper (19) as shown (facing the fixed sash).
- (5) Push top stopper (19) onto the guide track as shown.
- (6) Pivot single sash (active sash) with the guide track into place.
- (7) Re-fasten guide track to the frame using screws 4.0 x 22 (alternatively, self-tapping screws 3.9 x 25).
- (8) Position top stopper (19) as shown and screw into place (⊛ T 25, 4 – 5 Nm).

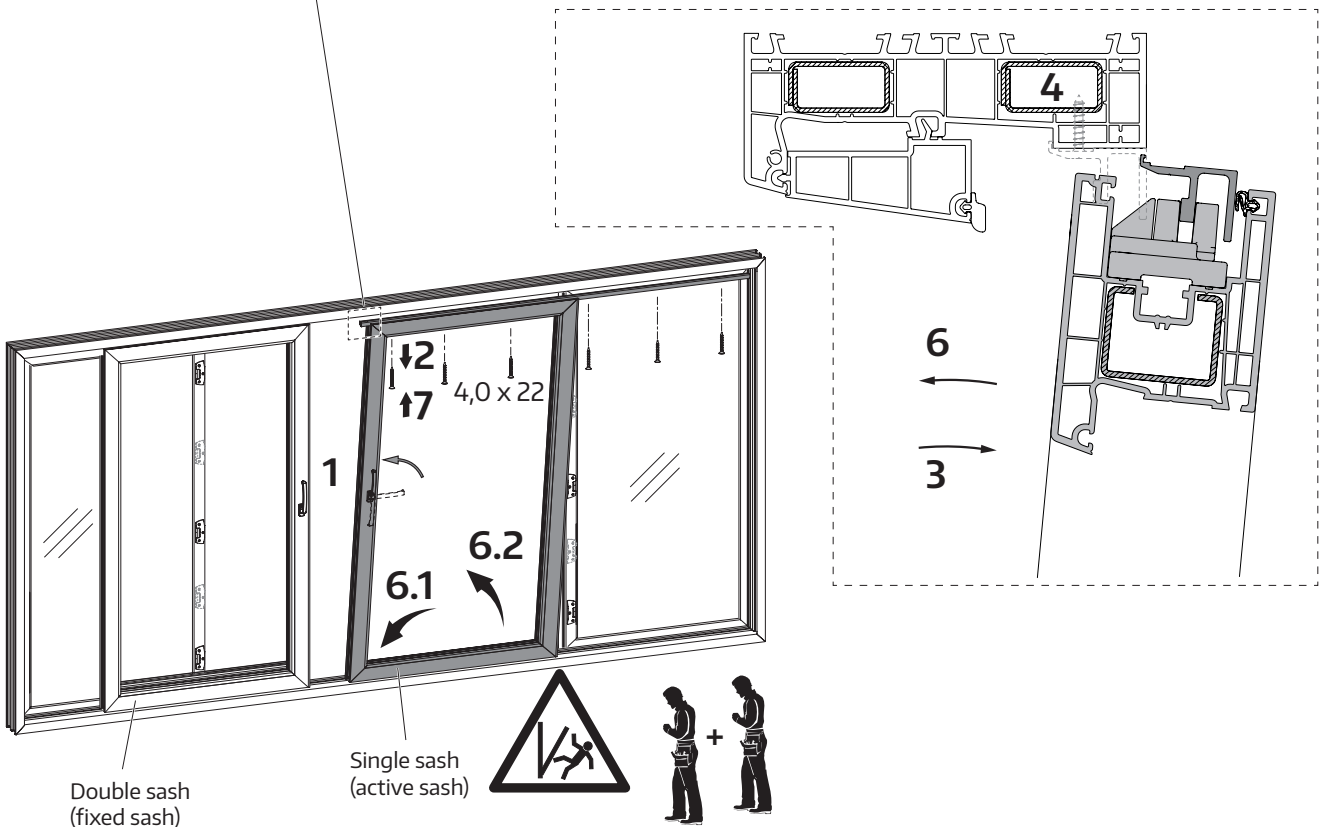
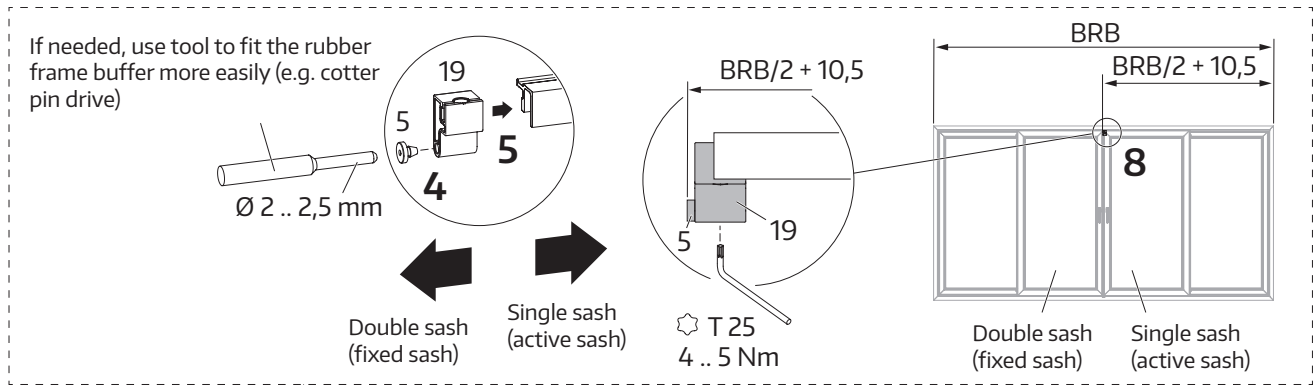

# Installing the sash buffer

- (1) Shim cover rails firmly on both flexible corners on the non-handle side. Ensure fitting parts can move freely.
- (2) Drill 2 holes 11 mm in diameter into the sliding sash cover rail and insert recesses into the cover rail as shown in the drawing.
- (3) Fit the cover rail.
- (4) Insert sash buffers into the cover rail holes.

Diagram: Scheme A;  
on both sliding sashes in the  
same way for Scheme C

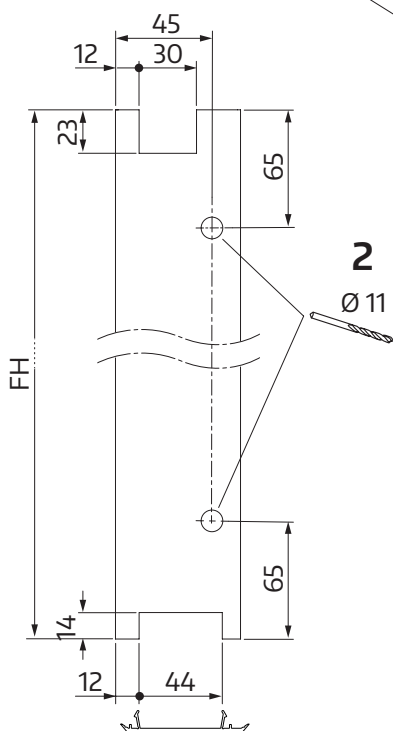
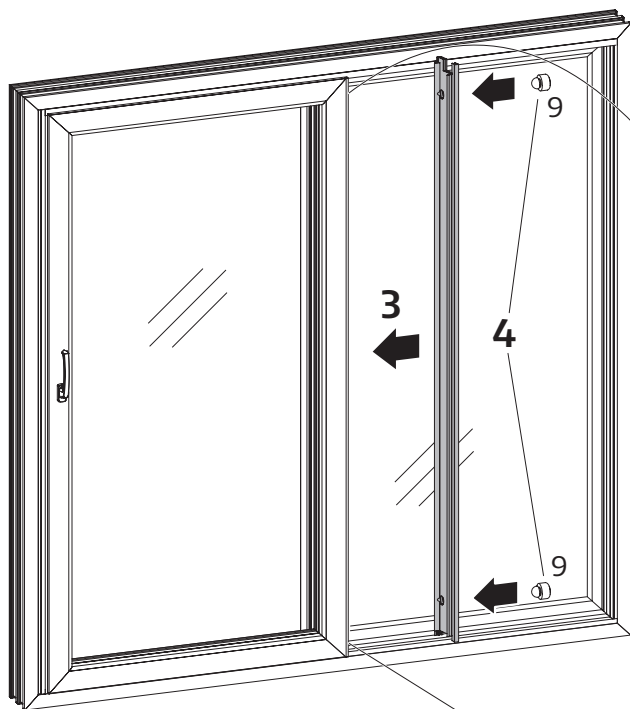

## 1.1 Recommendation for shimming (on site)

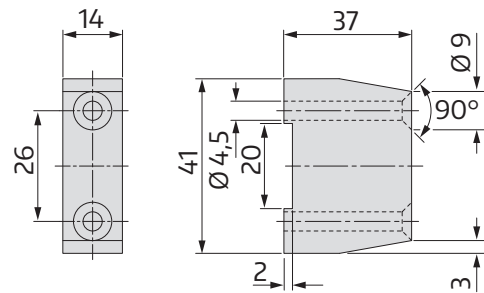

## 1.2

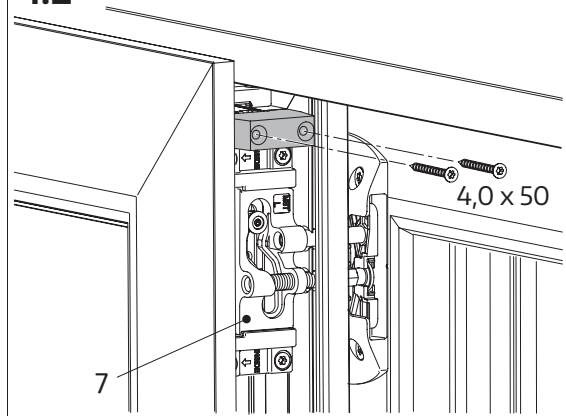

## 1.3

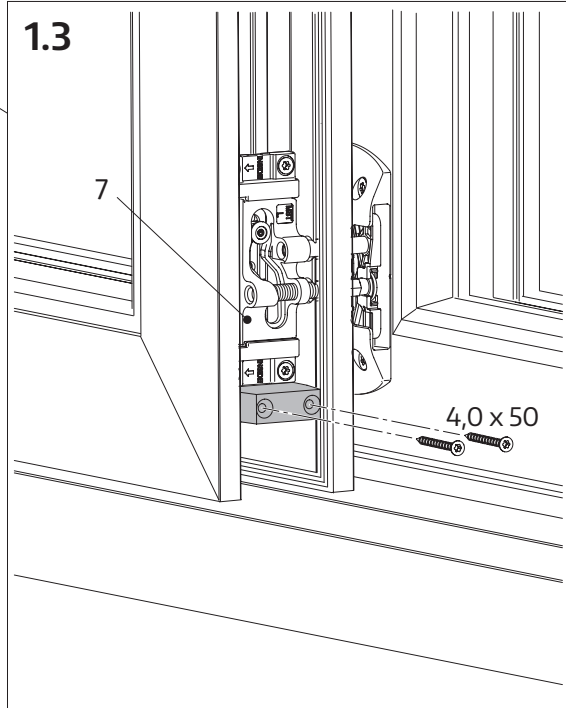

# Fitting optional top sash buffer

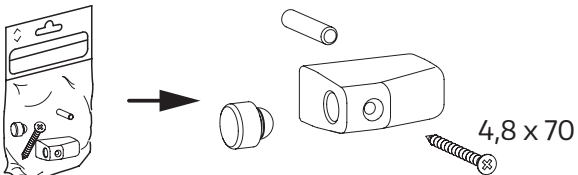
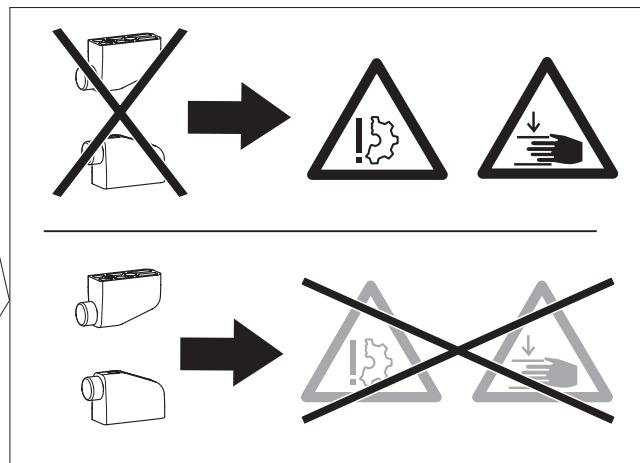
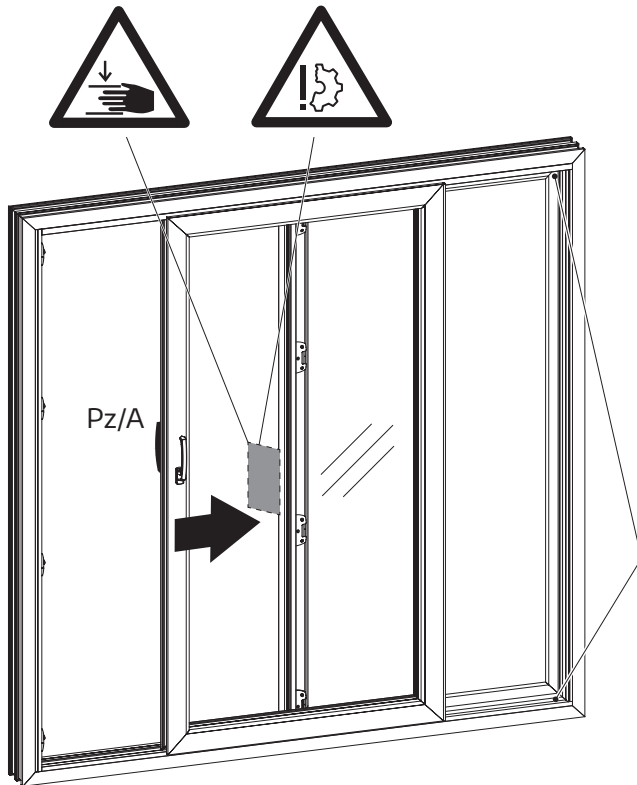

BZ top sash buffer		
Black	White	Grey
187477	187480	239855

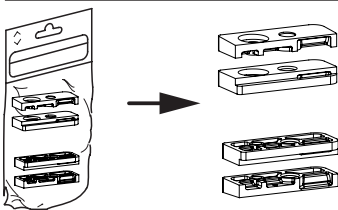

BZ shim for top sash buffer		
Black	White	Grey
306564	306563	306565



# Fitting optional top sash buffer (contd.)

Two stopper parts are installed per fixed sash.

- (1) Slide the sliding sashes open as far as shown.
- (2) Insert the bolt  $\text{Ø} 8.0 \times 50$  and the sash buffer into the corresponding stopper part.
- (3) Drill the holes for the bolt 8 mm in diameter (if necessary drill  $\text{Ø} 8.2$ ) and the screw 4.2 in diameter (also Y and Z views).

With drilling template: push shim with drilling template against the sliding sash cover rail and drill holes for bolt and screw.

- (4) Fasten the stopper parts and shims with screws  $4.8 \times 70$ .

**i** Important note:  
A different shim must be used for the top stopper part from the lower stopper part.

Diagram shows lower sash buffer only (measurements apply to both sash buffers)

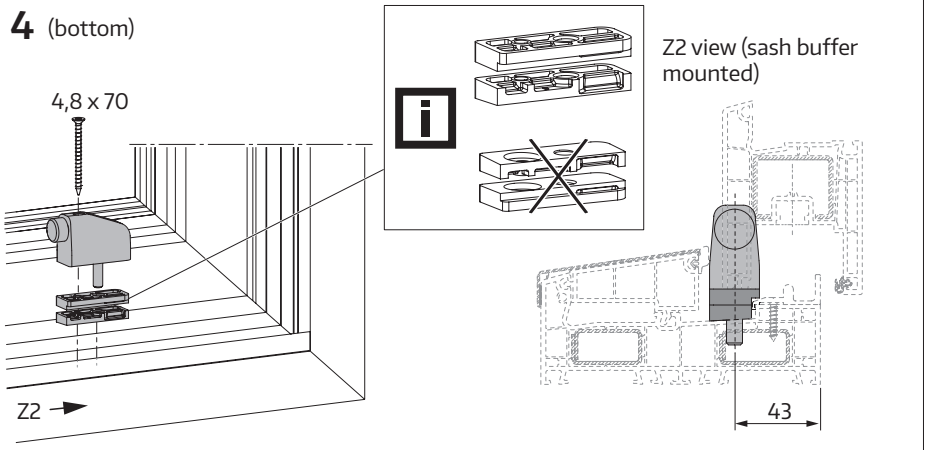
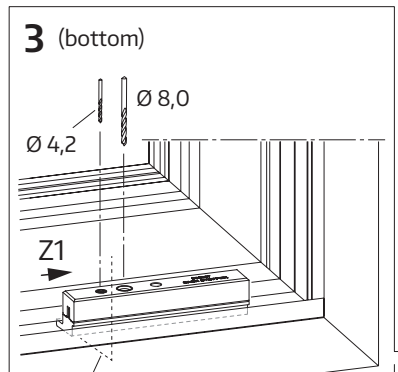
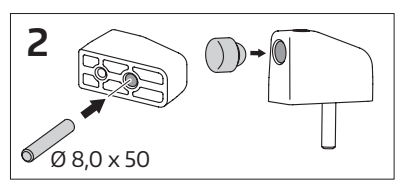
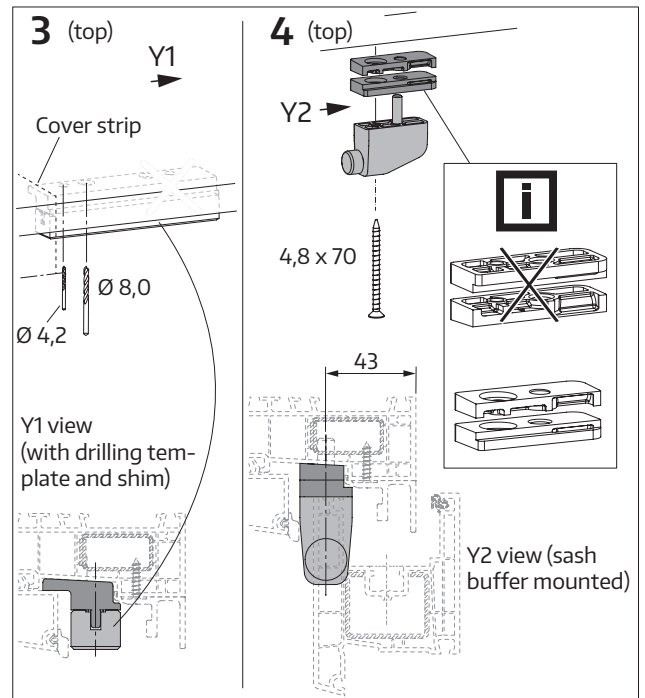
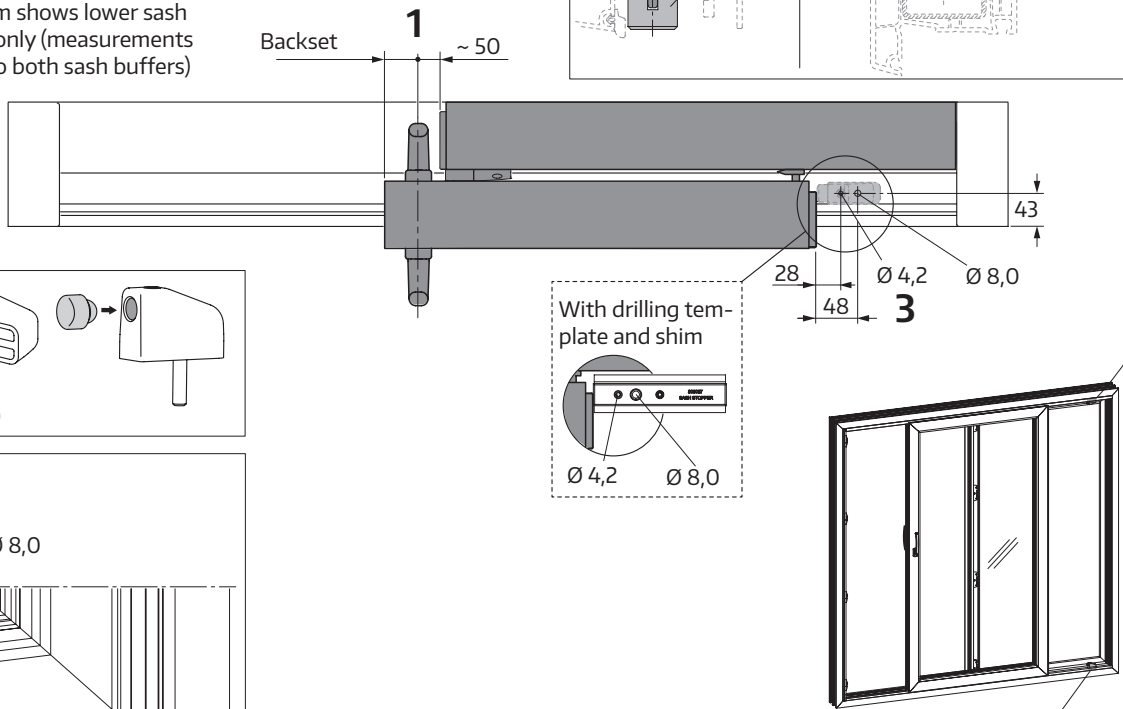

# Fitting optional recess handle

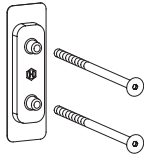

Scheme A: 1x  
Scheme C: 2x

Z view

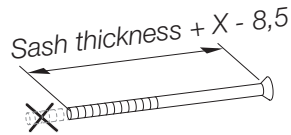
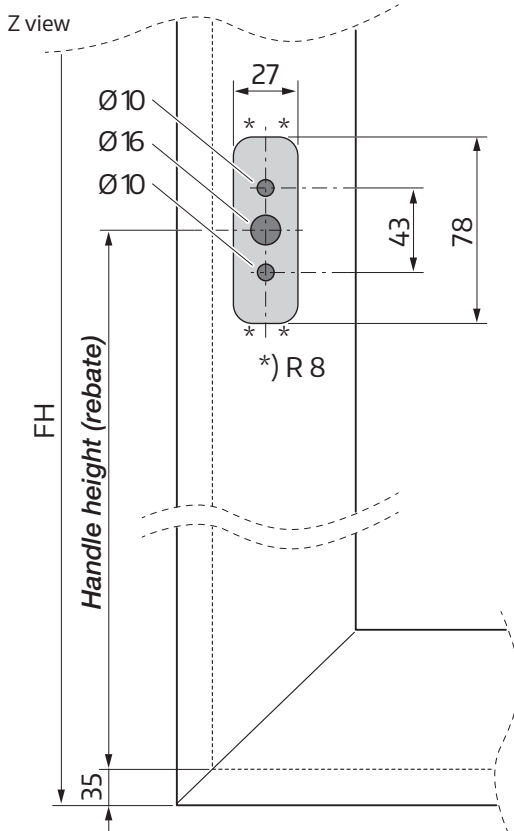

SRH	Handle height (rebate)
470– 800	1/2 SRH
801– 1250	1/2 SRH
1251– 1350	1/2 SRH
1351– 1540	544.5
1541– 1650	644.5
1651– 1900	994.5
1901– 2150	994.5
2151– 2400	994.5
2401– 2500	994.5

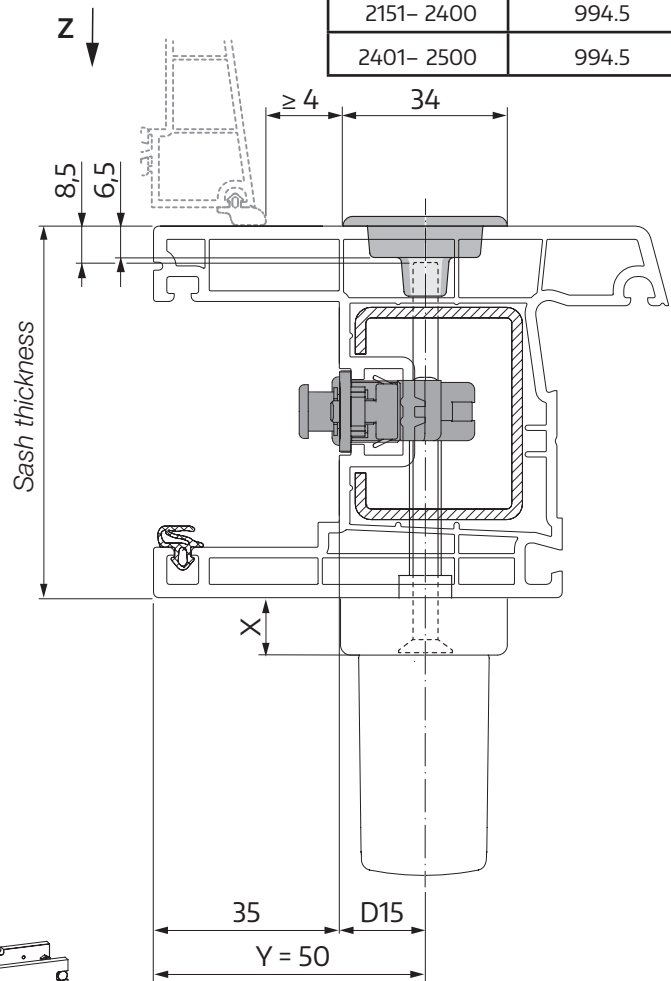

Use drilling template  
(item code 250443)

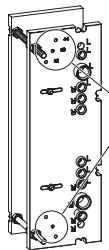

Setting Y dimension

Use with right-hand version  
= DIN EN 12519 left  
(opens to left)

Use:

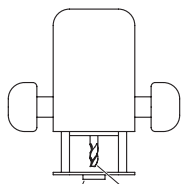

Outlet ring Ø 27

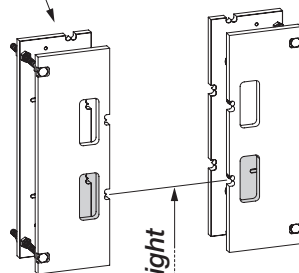

Handle height (rebate)

Use with left-hand version  
= DIN EN 12519 right  
(opens to right)

# Fitting optional handle 161 GE-Pcl/160 GE-PcO (recommended if optional top sash buffers are used)



**Important note:**  
For profiles with a maximum installation depth of 90 mm. The additional (optional) sash buffers at the top and bottom must be adjusted accordingly so that the PzO handle does not hit the fixed panel; otherwise, you may cause material damage.

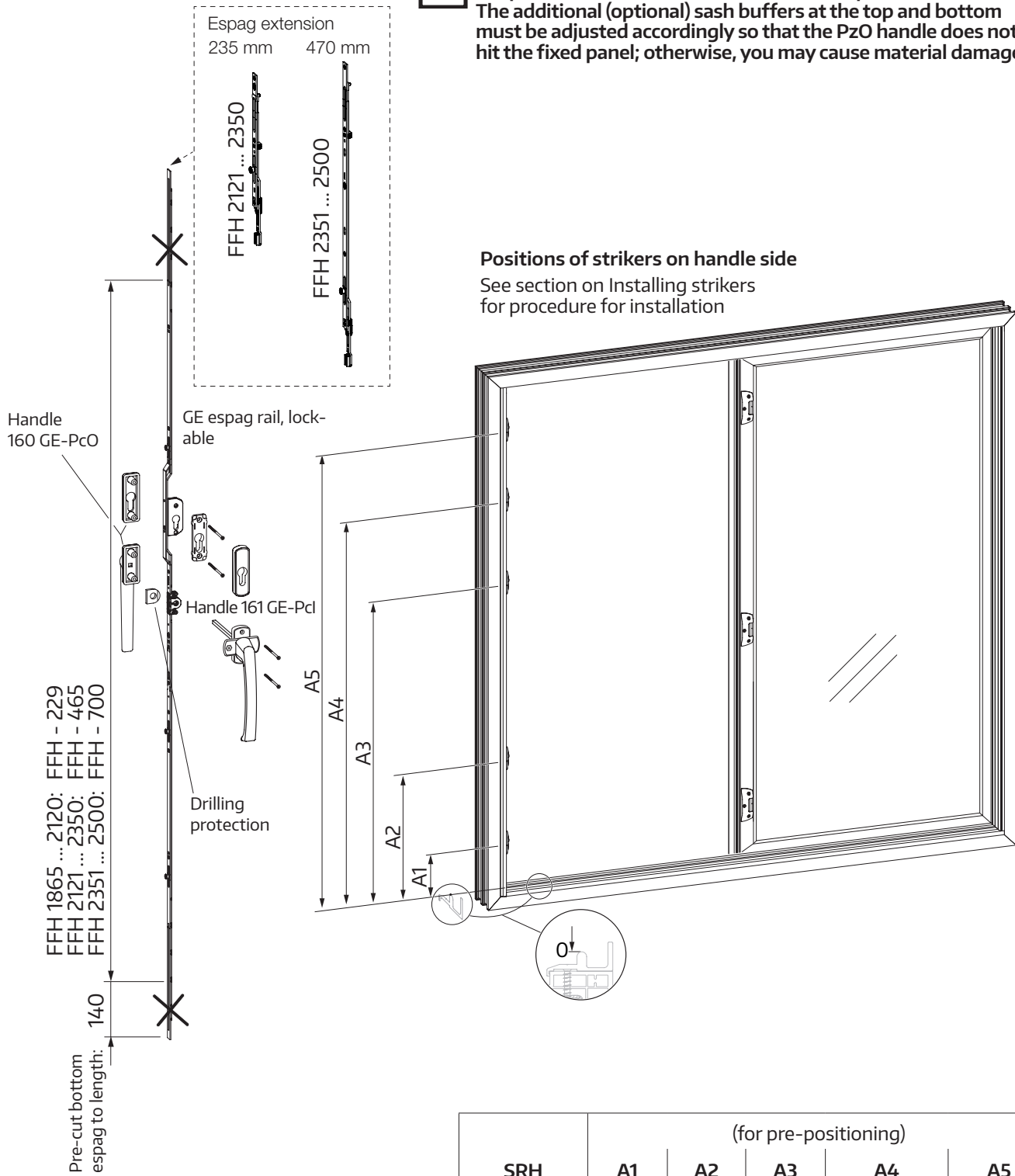

SRH	(for pre-positioning)				
	A1	A2	A3	A4	A5
1865- 2120	100	725	1389.5	-	SRH - 40
2121- 2350	100	725	1389.5	-	SRH - 40
2351- 2500	100	725	1389.5	SRH - 253.5	SRH - 40

# Fitting optional handle 161 GE-Pcl/160 GE-PcO (contd.)

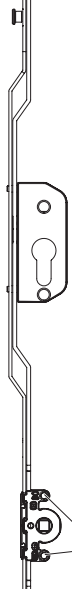

Ø 5,5 Pzl + PzA

**Handle 161 GE-Pcl**



X = Ø 4,2

**Handle 160 GE-PcO**

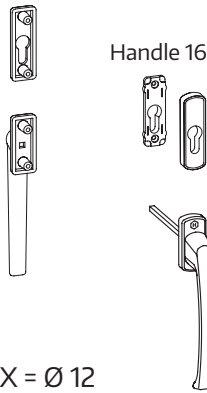

X = Ø 12

**Detail A**

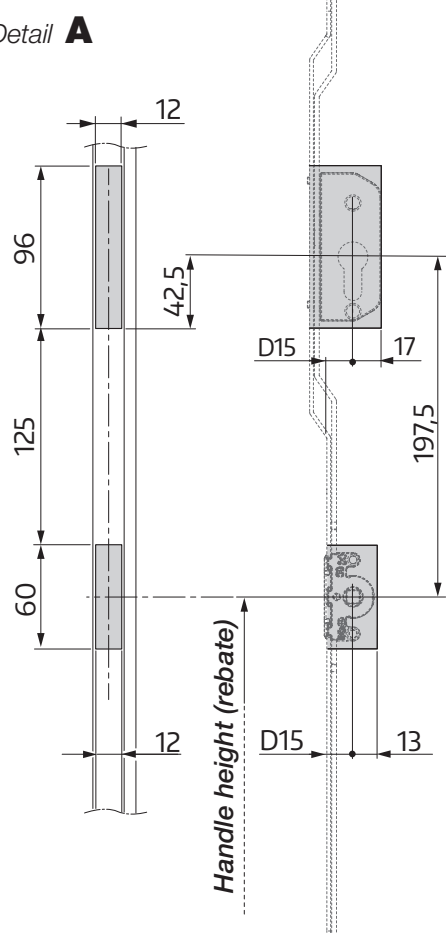

**Use drilling template (item code 250443)**

Use:



Ø 12  
Ø 20

**1** Setting Y measurement (see page 34)

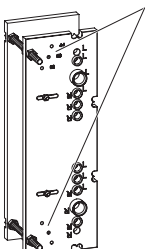

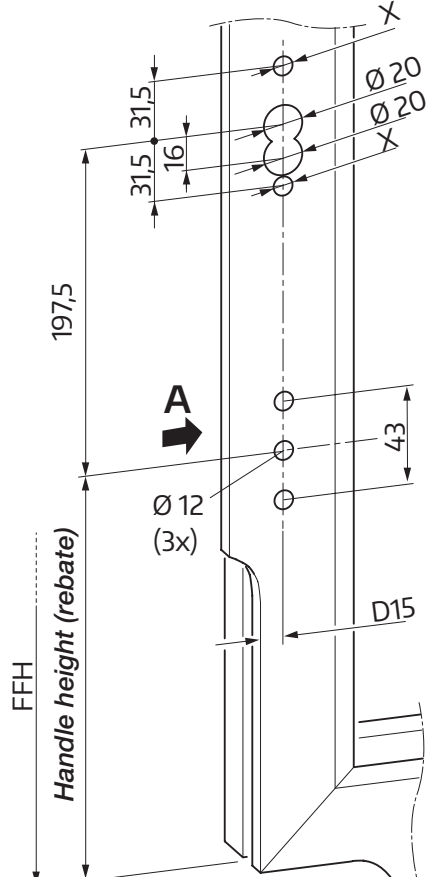

Use with left-hand version = DIN EN 12519 right (opens to right)

Use with right-hand version = DIN EN 12519 left (opens to left)

**2**

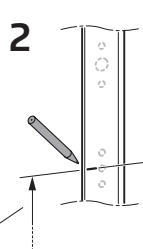

**3**

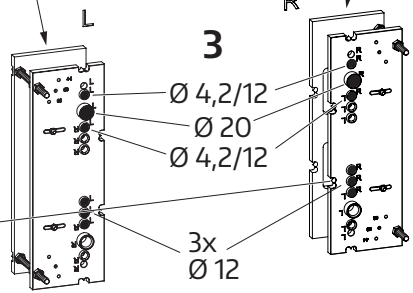

Ø 4,2/12  
Ø 20  
Ø 4,2/12  
3x Ø 12

**4.1**

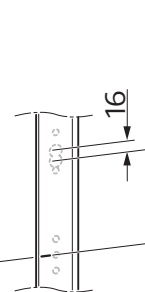

16 mm

**4.2**

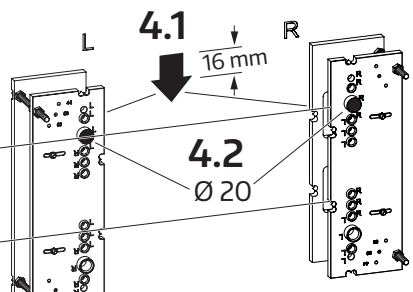

Ø 20

SRH	Handle height (rebate)
1865- 2120	994.5
2121- 2350	994.5
2351- 2500	994.5

# Fitting optional handle 161 GE-Pcl/160 GE-PcO (contd.)

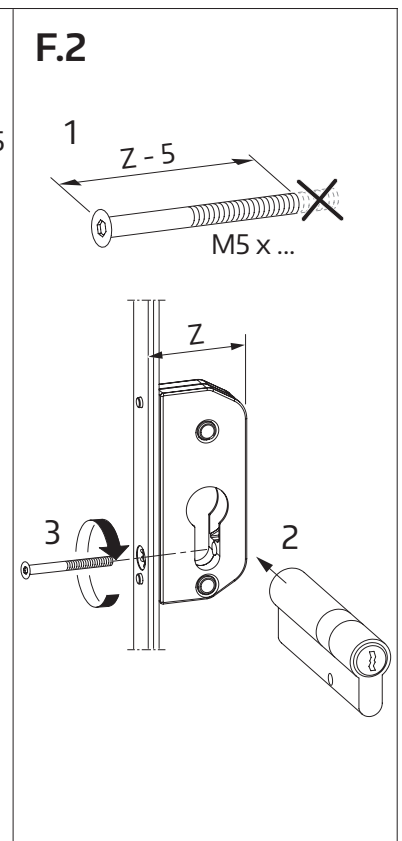
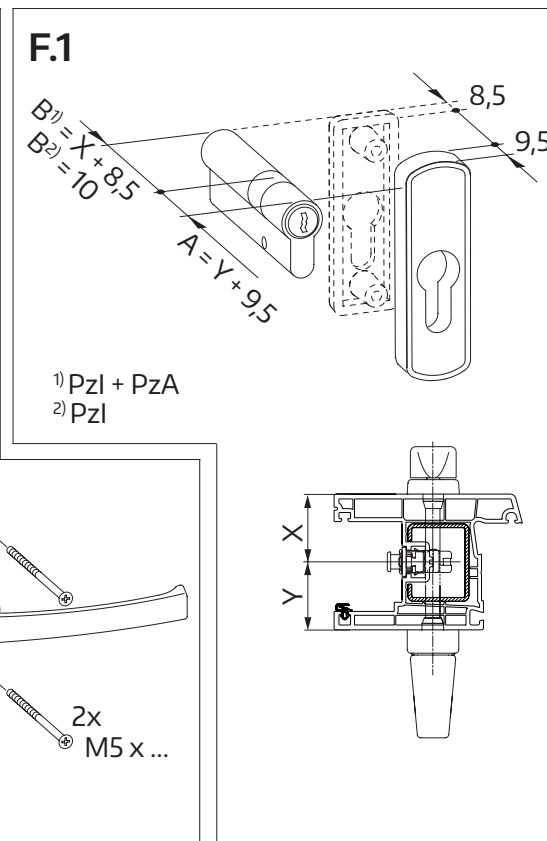
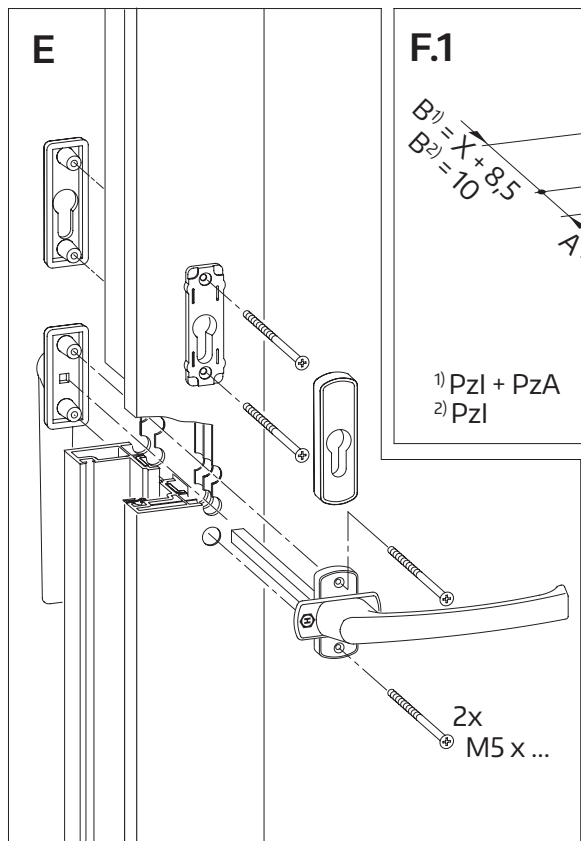
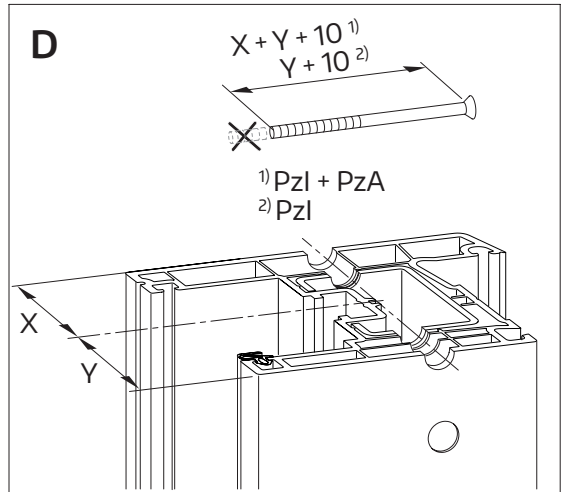
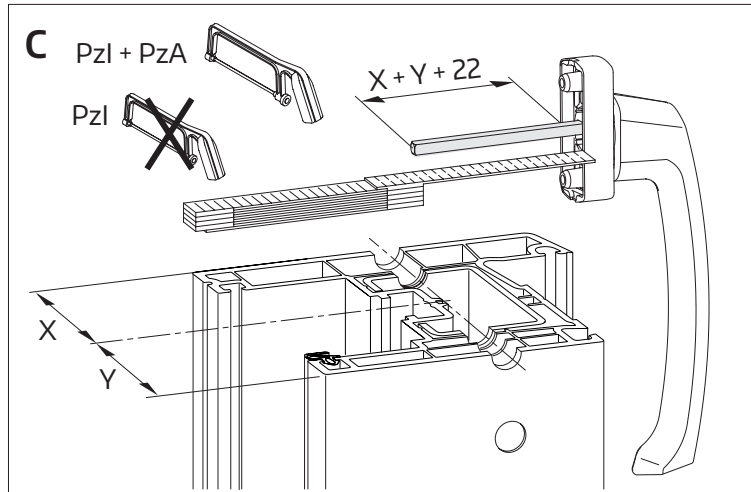
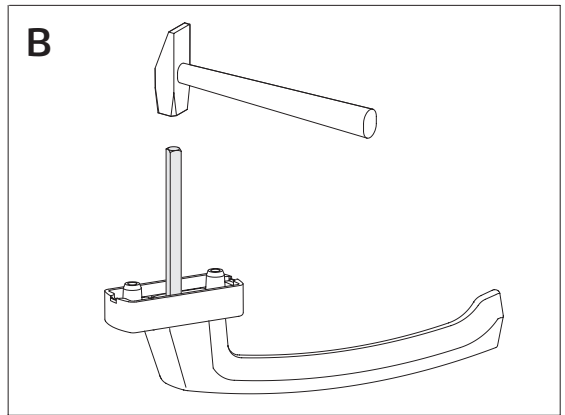
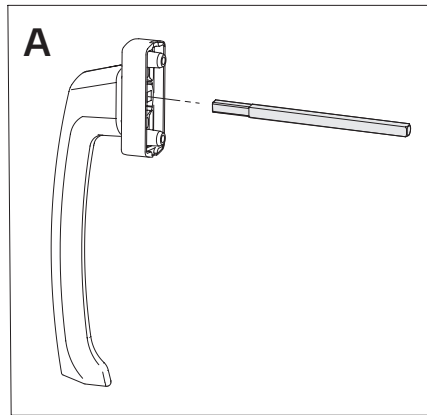
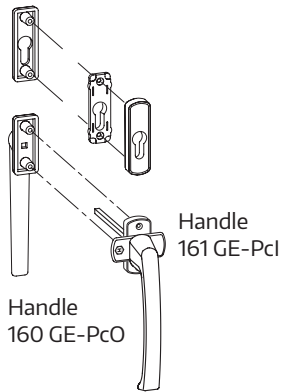

# Sash contact pressure adjustment

- (1) Handle side: check the sash locking behaviour. Adjust the sash contact pressure by adjusting the overlap height (14 mm) using T 15 on all locking pins on the espag and the flexible corners on the handle side.
- (2) Central stile: check the sash locking behaviour. Adjust the sash pressure by adjusting the dimension 14 mm using a size 8 spanner on all locking parts MST (adjustment in sliding position).

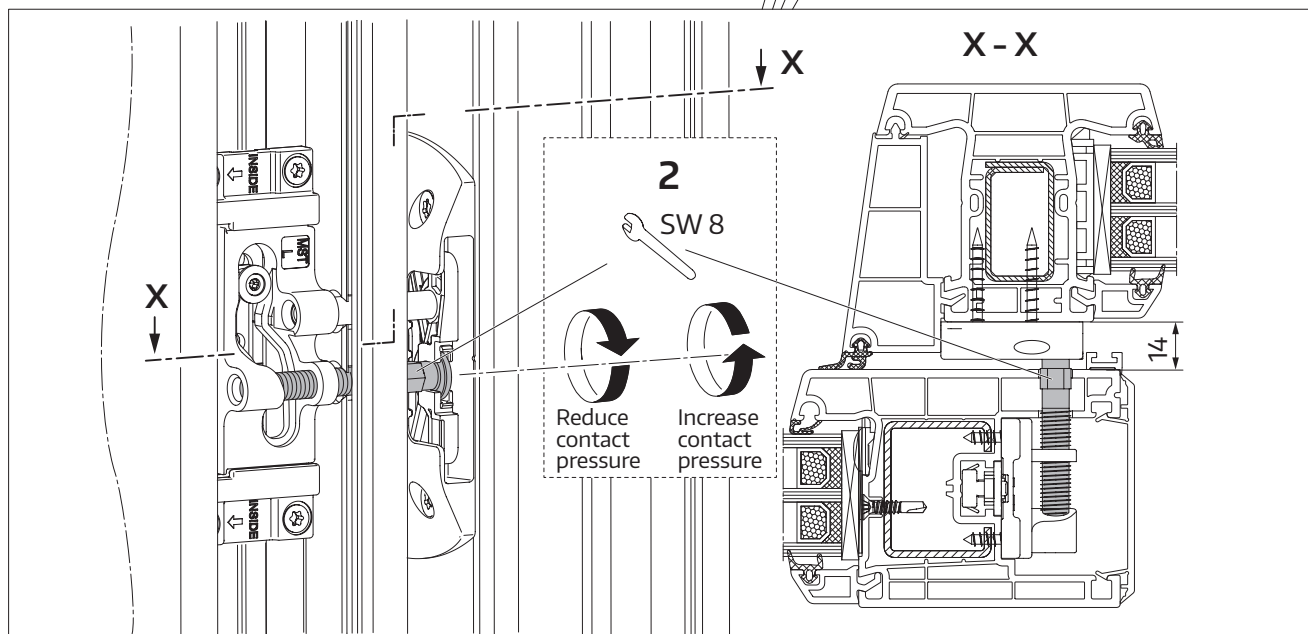
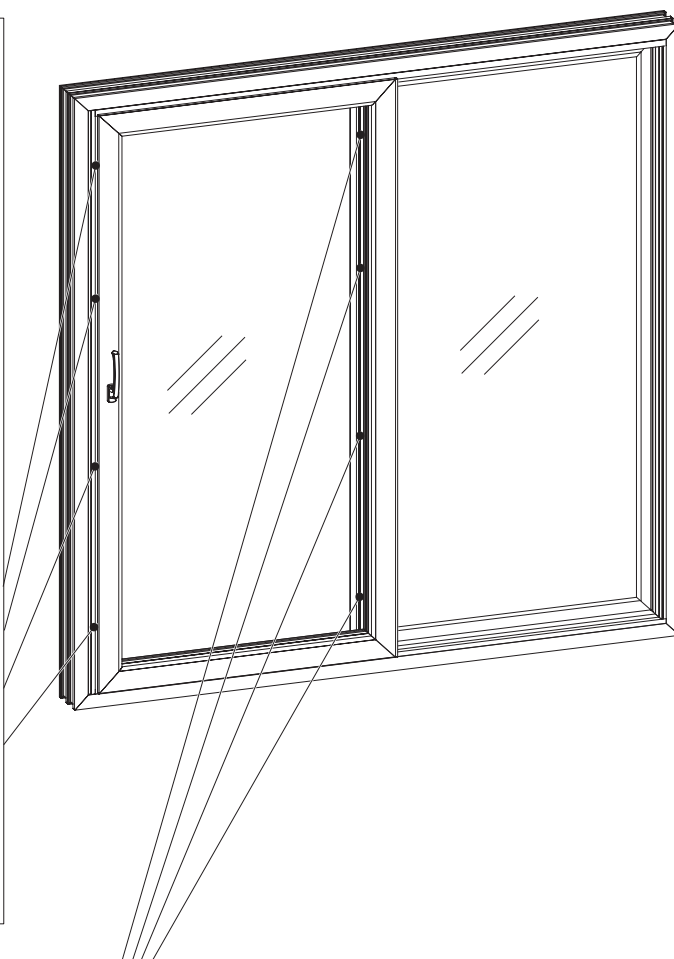
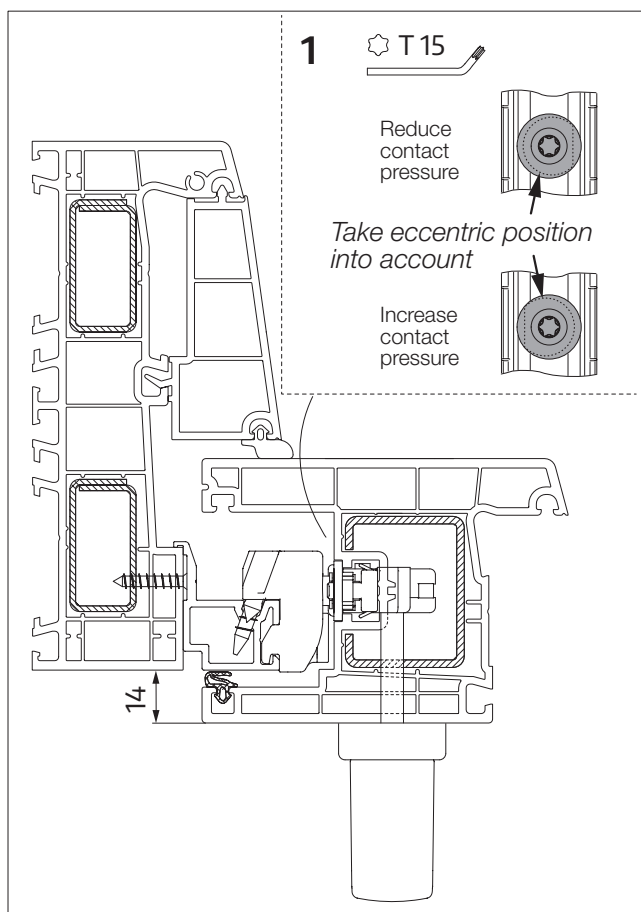

# Overview of vertical cross-section

Not to scale

Sash closed

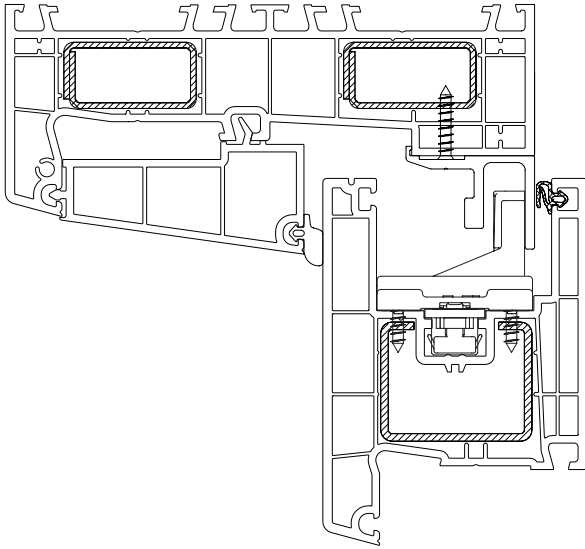

Sash in parallel position ( $\approx 6$  mm)

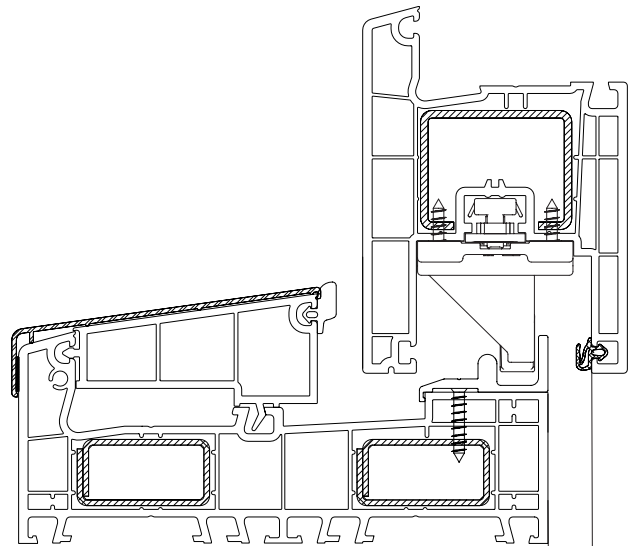
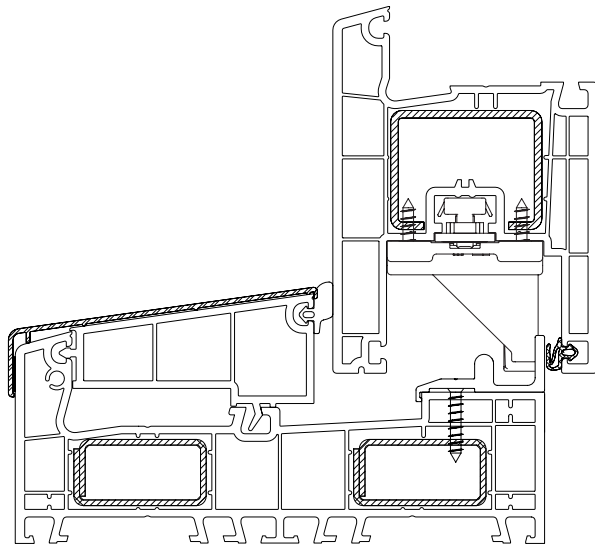
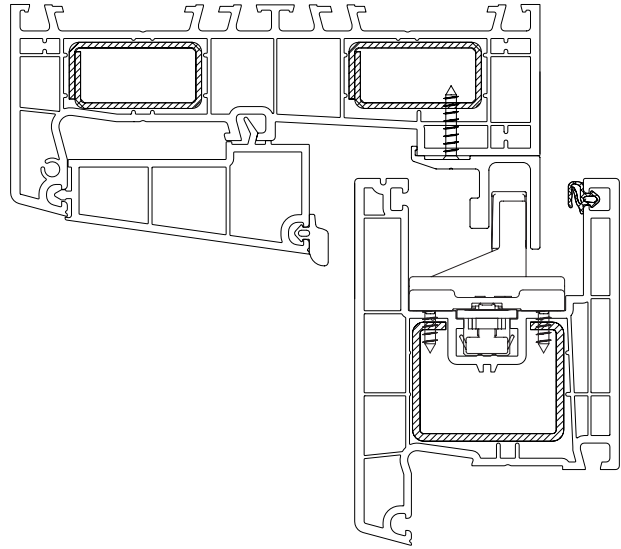

Opening width  $\approx 6$

# Horizontal cross-section of handle

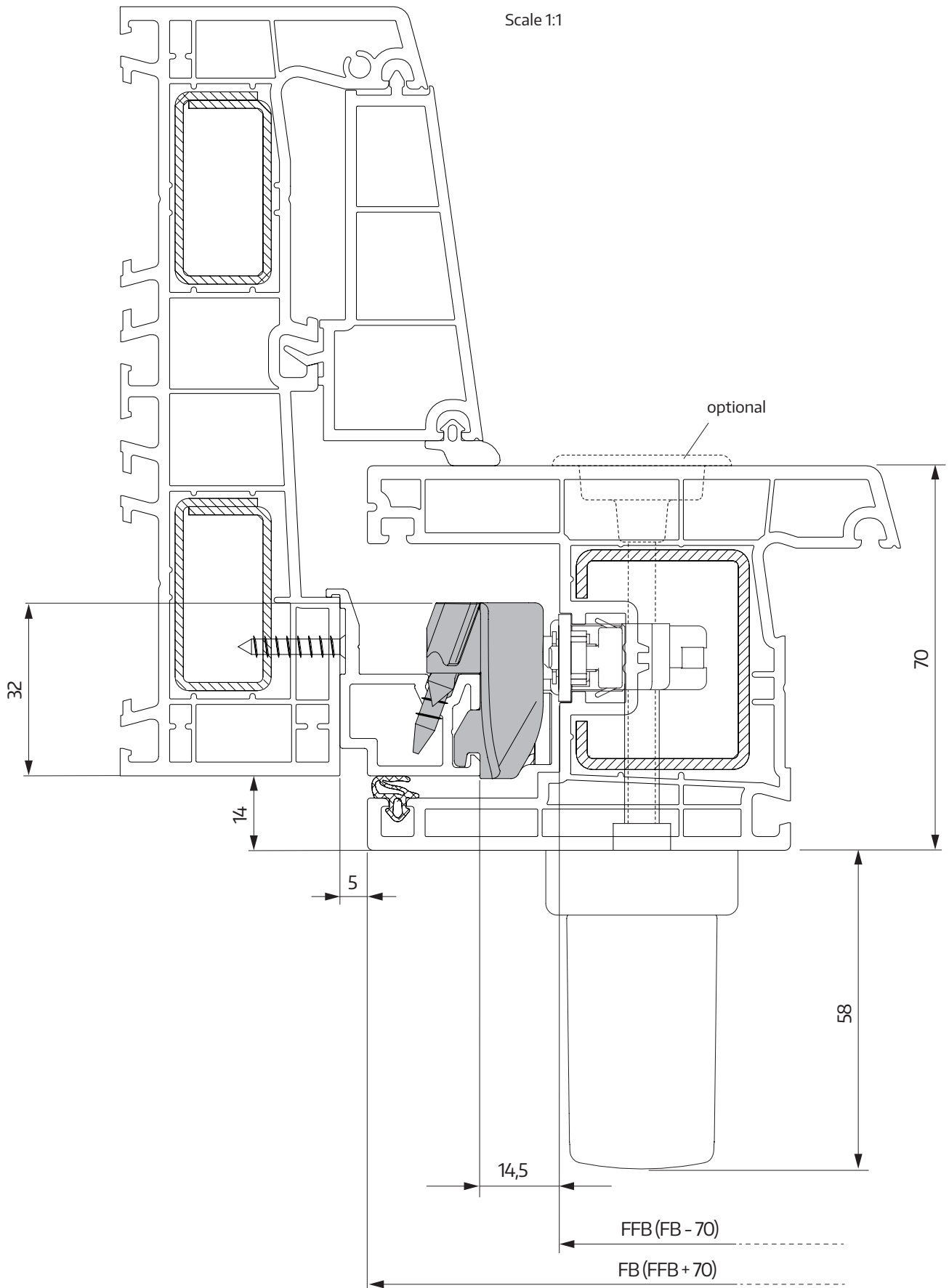



# Horizontal cross-section of central stile

Scale 1:1

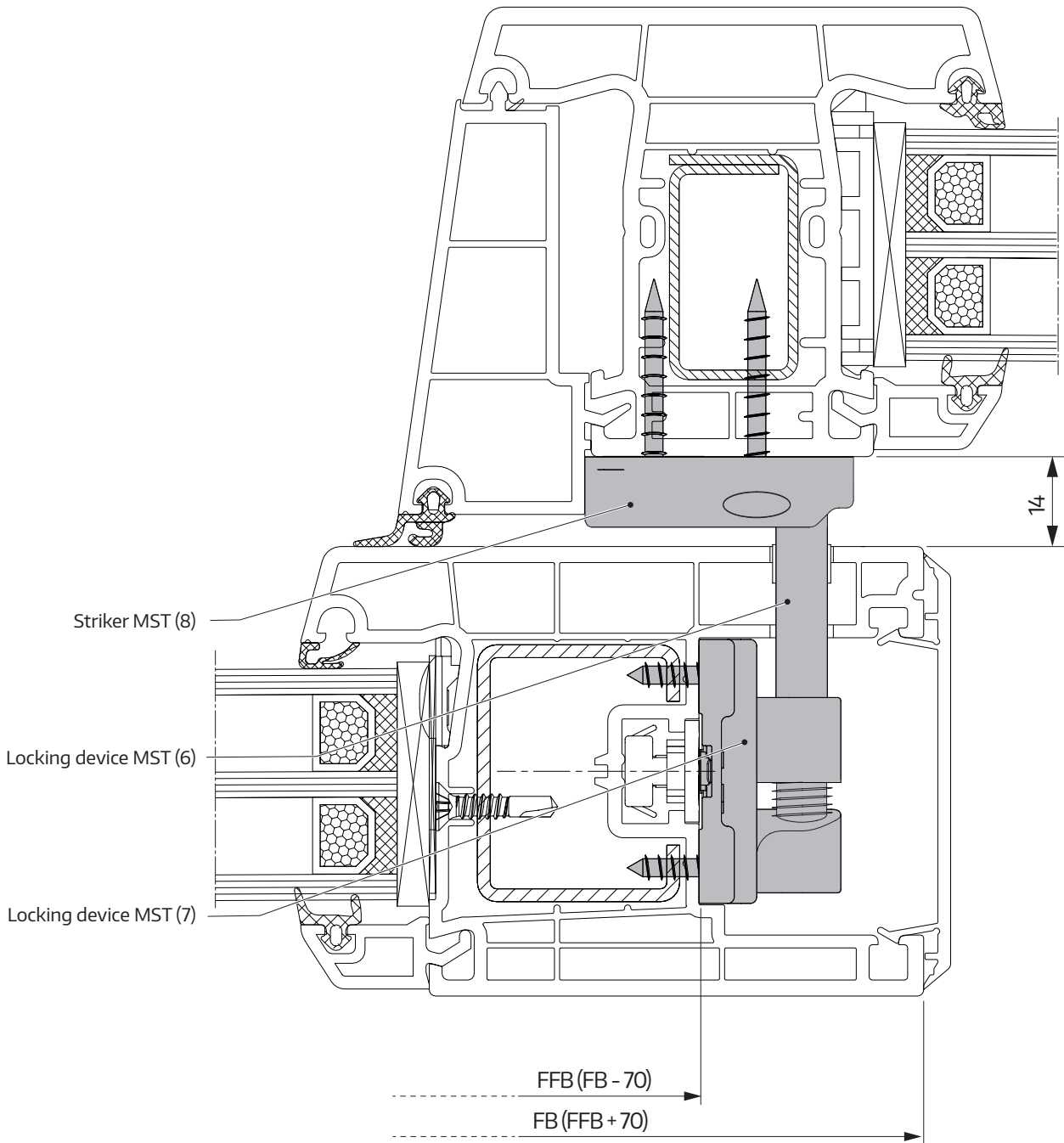

# Vertical cross-section of top guide

Scale 1:1

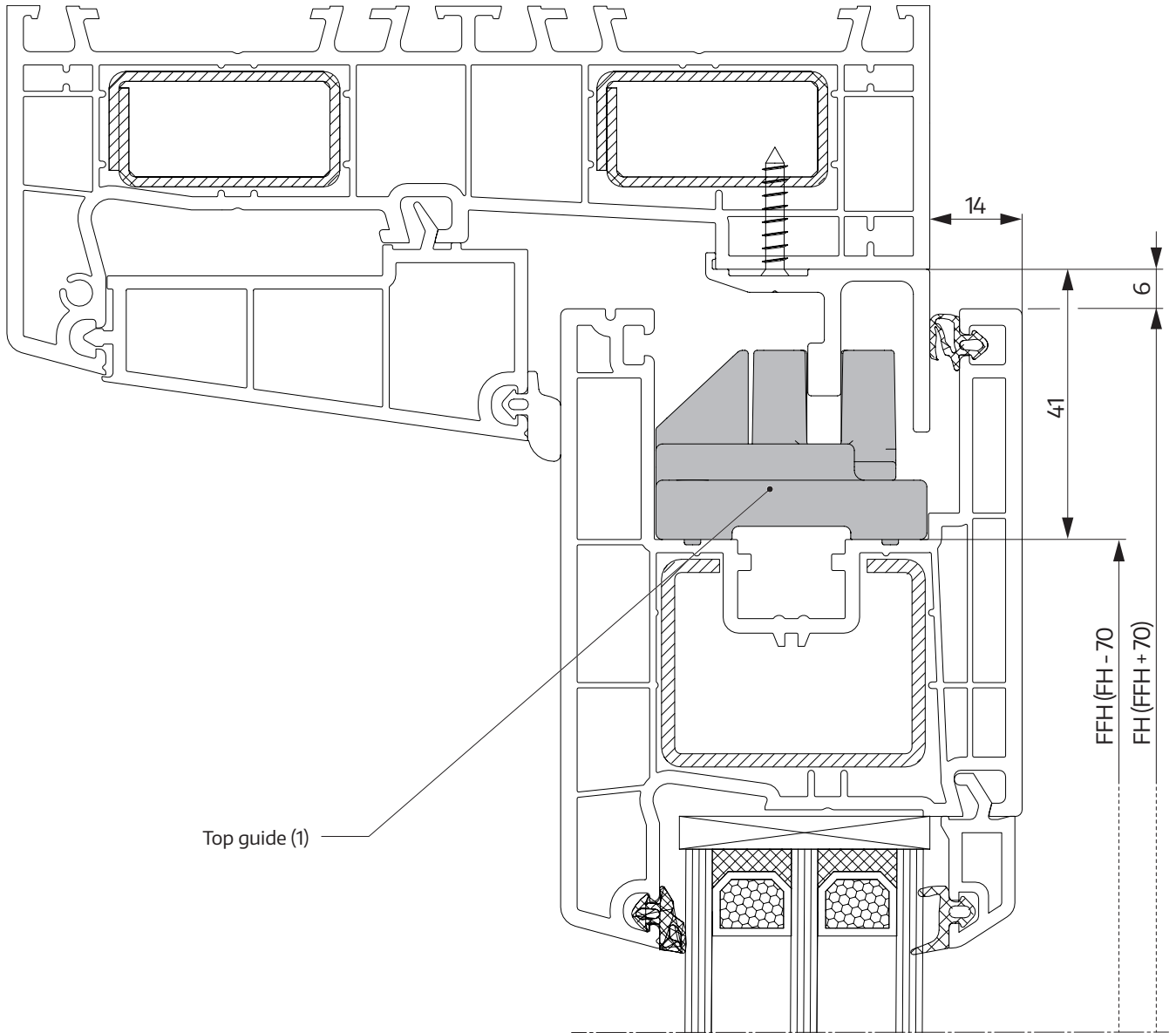

# Vertical cross-section of bogie

Scale 1:1

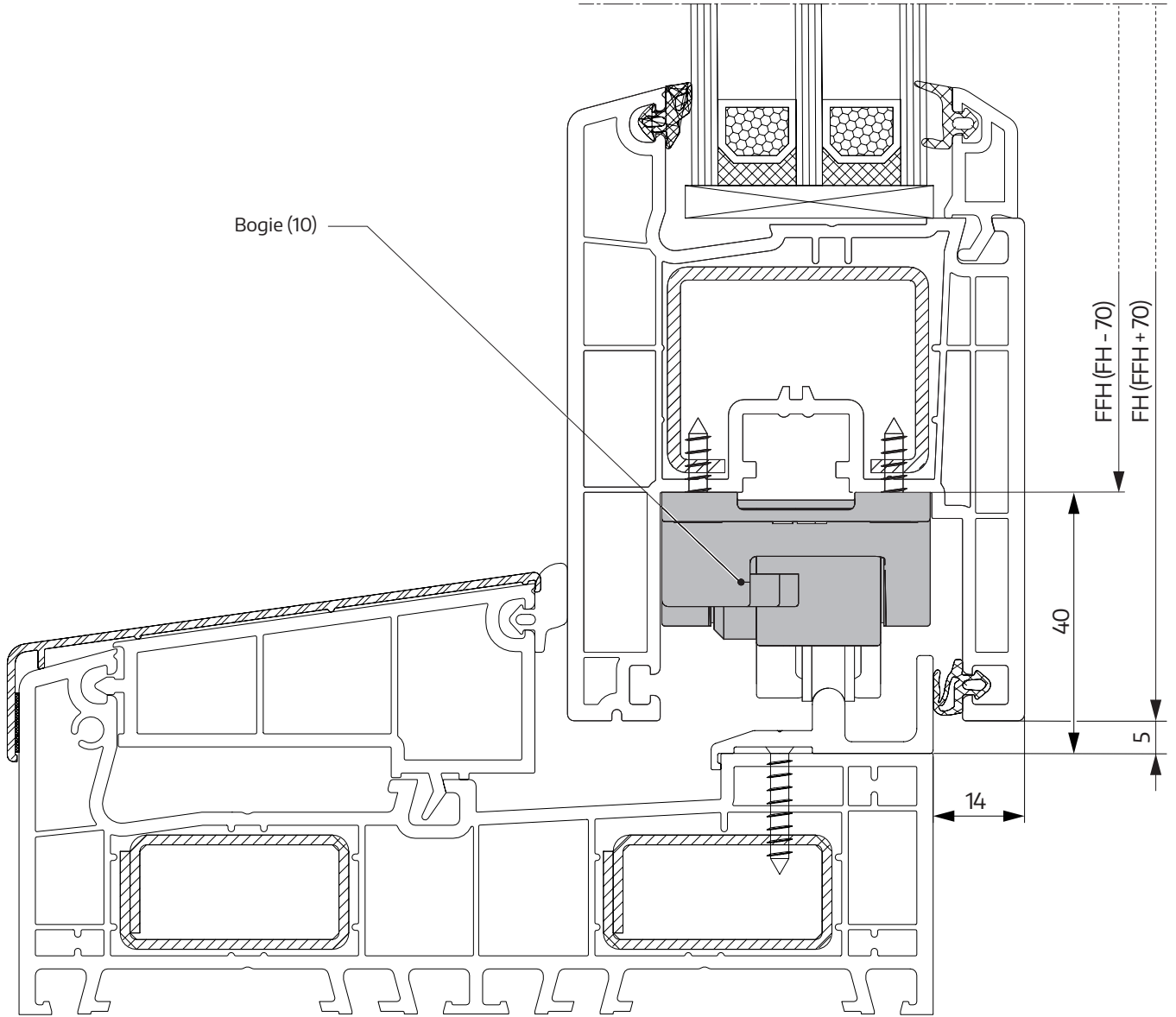

# Vertical cross-section of top locking device(s)

Scale 1:1

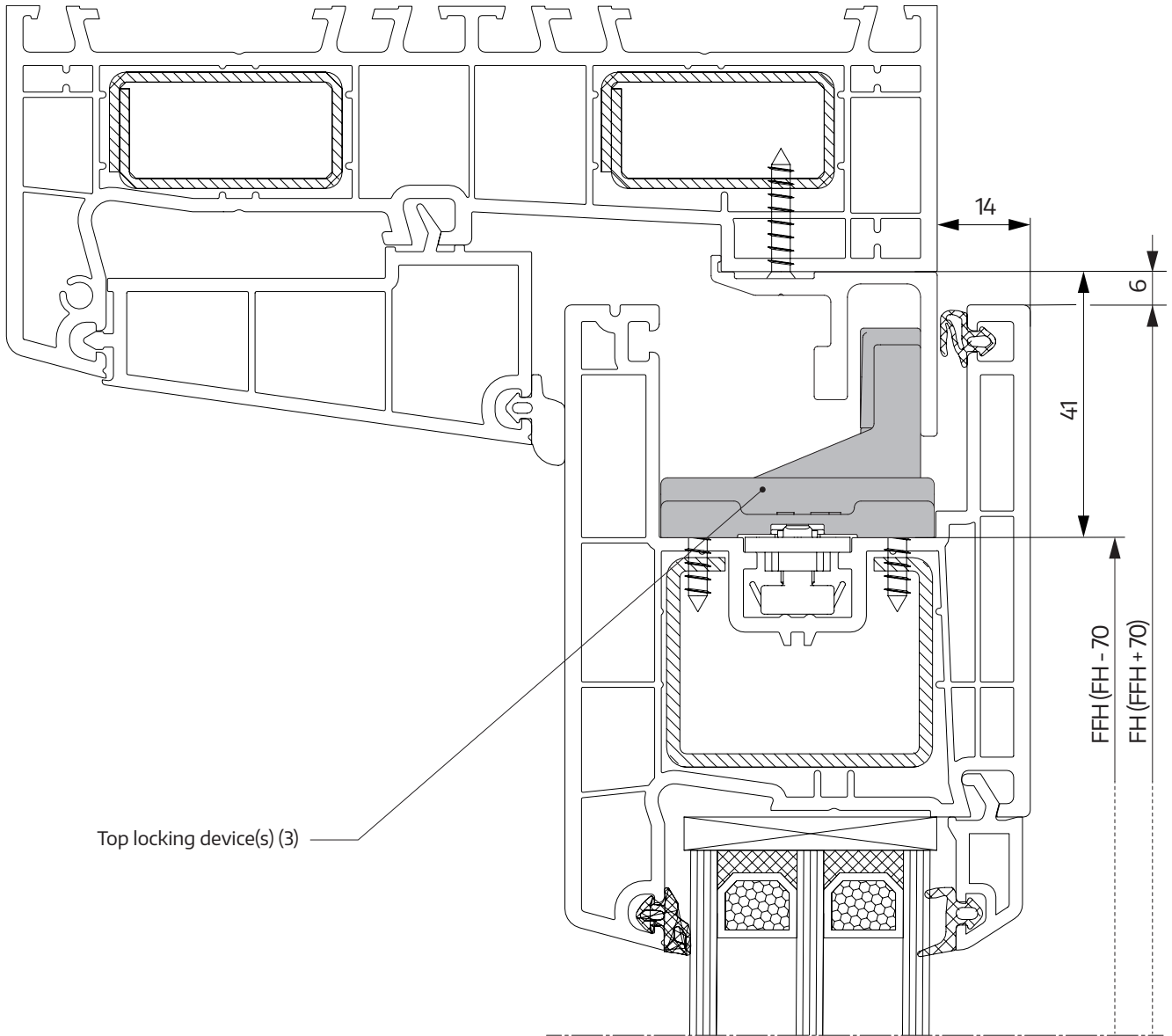

# Vertical cross-section of lower locking device(s)

Scale 1:1

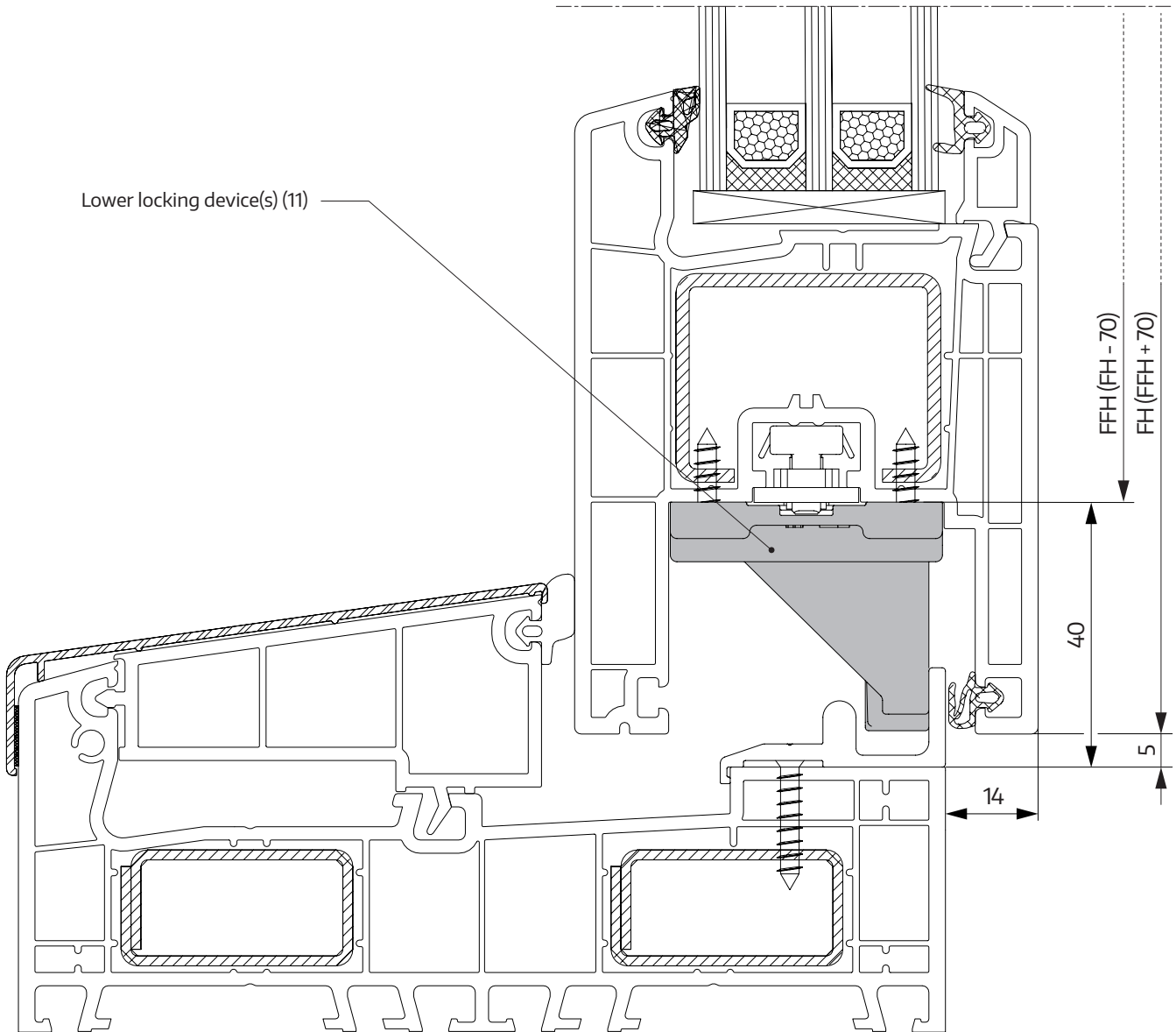

# Horizontal section Scheme C

Scale 1:1

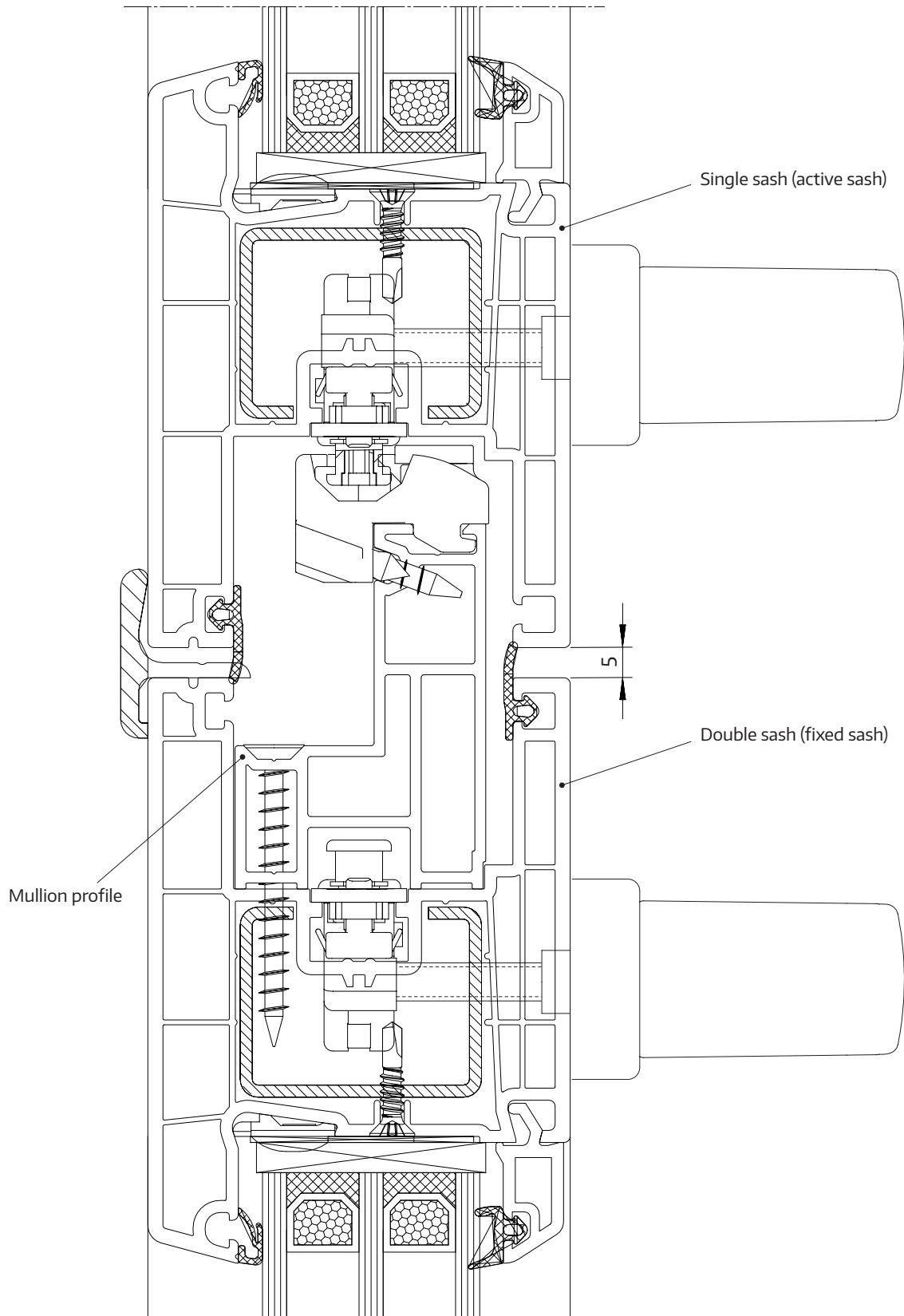



**HAUTAU in your area:**

<https://www.hautau.de/en/contact>

HAUTAU GmbH  
Wilhelm-Hautau-Straße 2  
D-31691 Helpsen  
Tel.: +49 5724 393-0  
E-Mail: [info@hautau.de](mailto:info@hautau.de)  
[www.hautau.de](http://www.hautau.de)



This document is continually updated.  
You find the latest version at <https://webdoc.hautau.de/download/77996>  
or scan the QR code.

Created: 08/2022 - Changed: 12/2024  
Order no. 501254  
All rights reserved. Subject to change.