

Sezioni battenti M 1:1

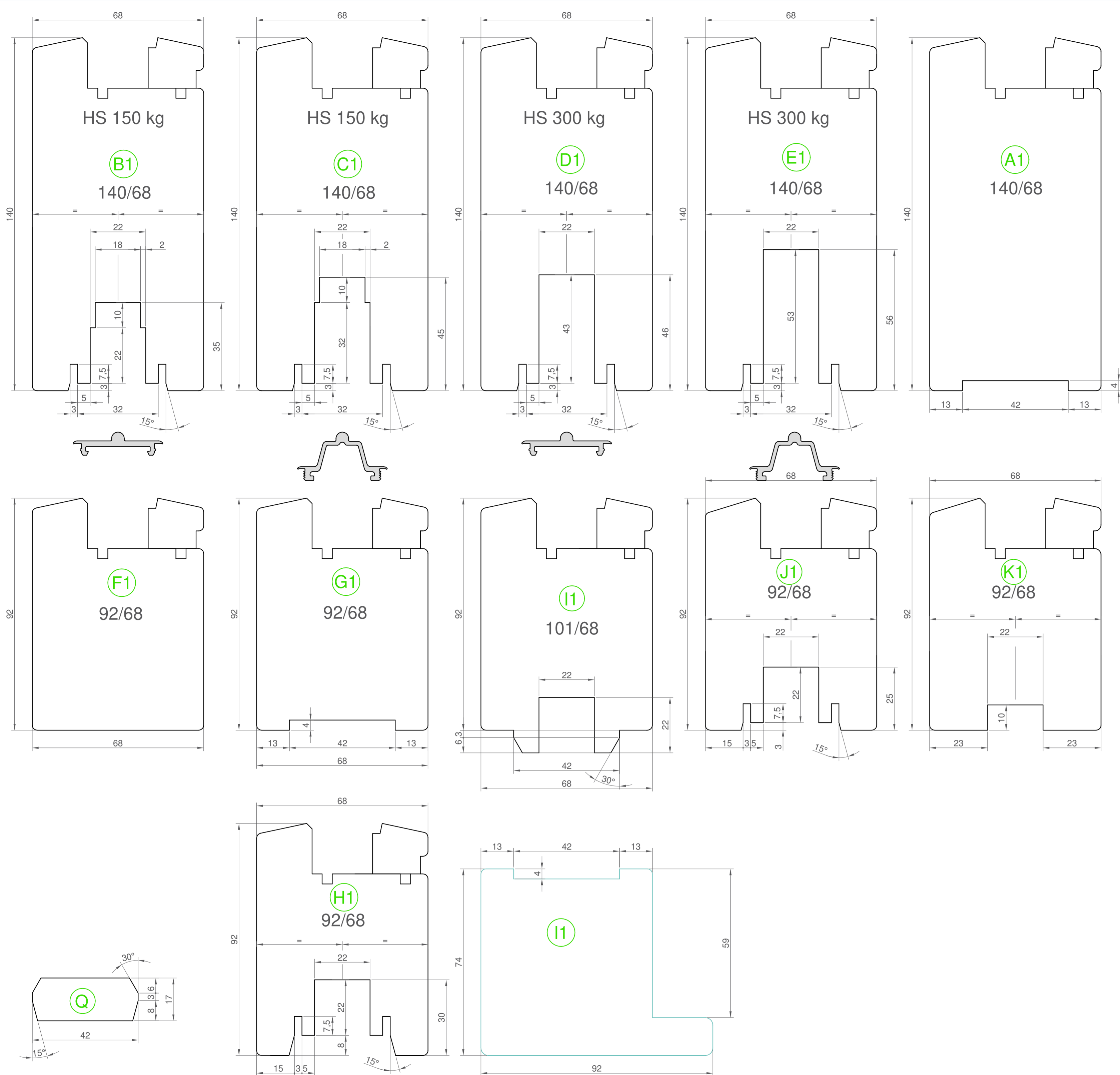

Sezioni Schema A M 1:1

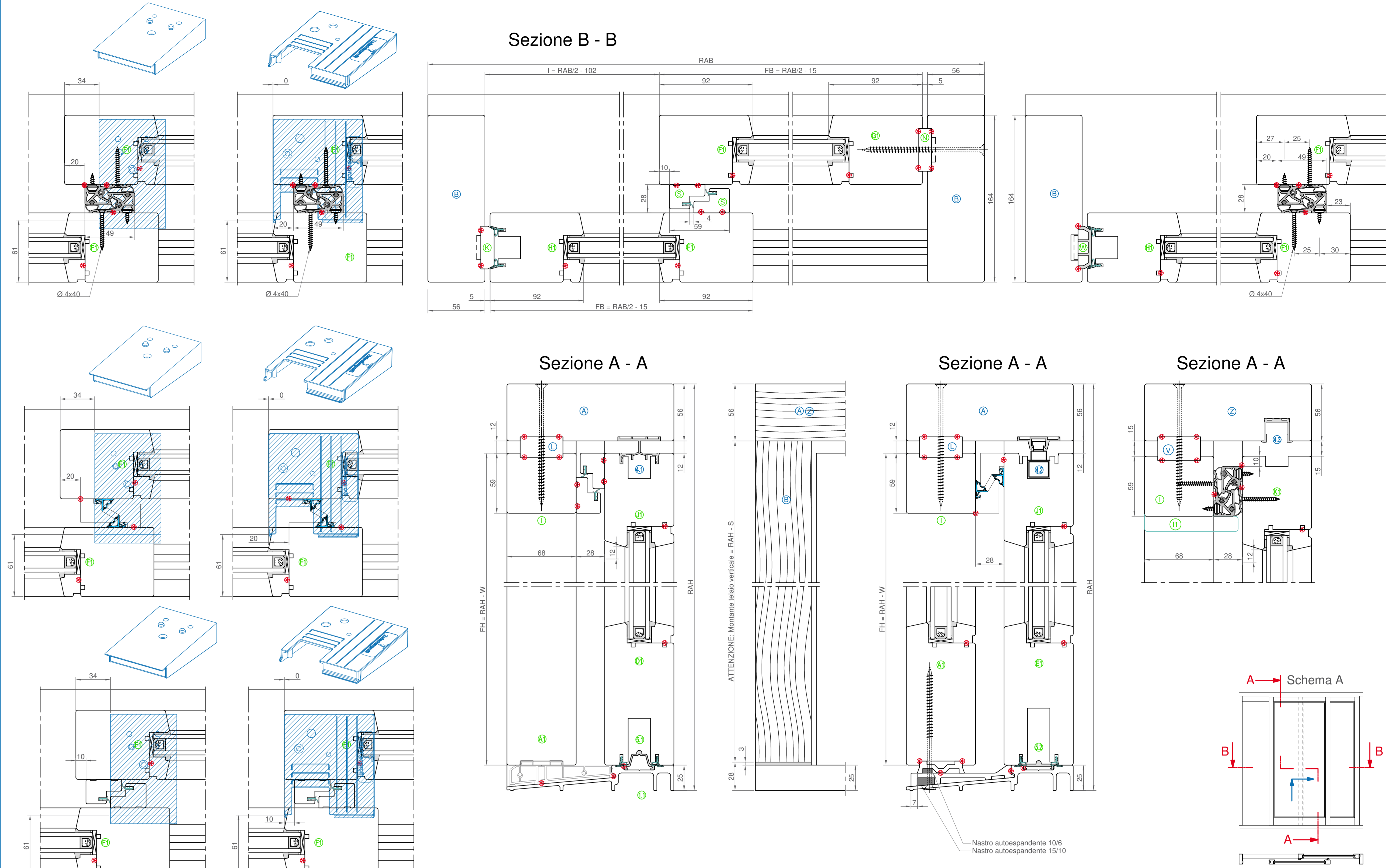

Sezioni telai M 1:1

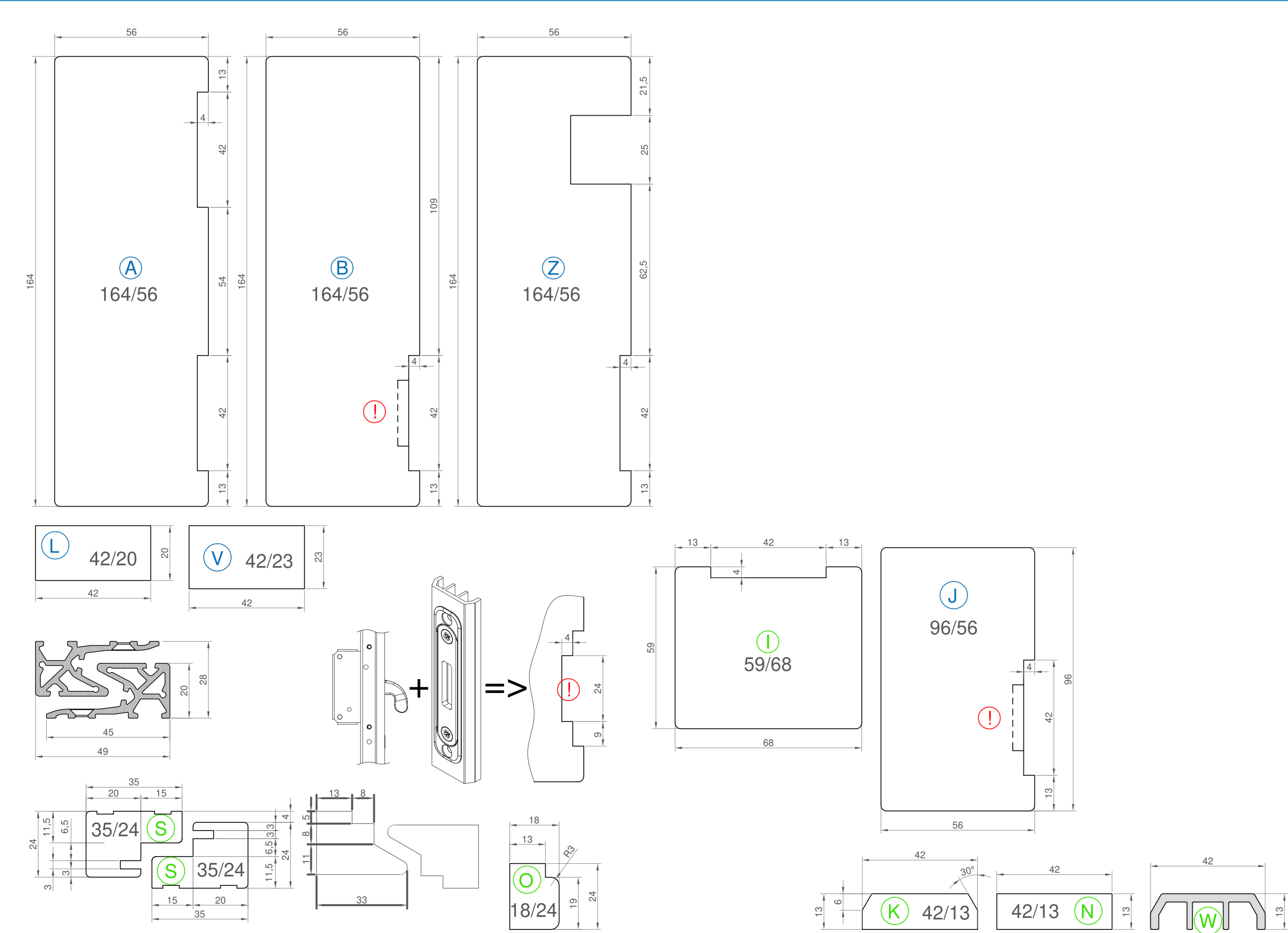

Particolari telaio M 1:1

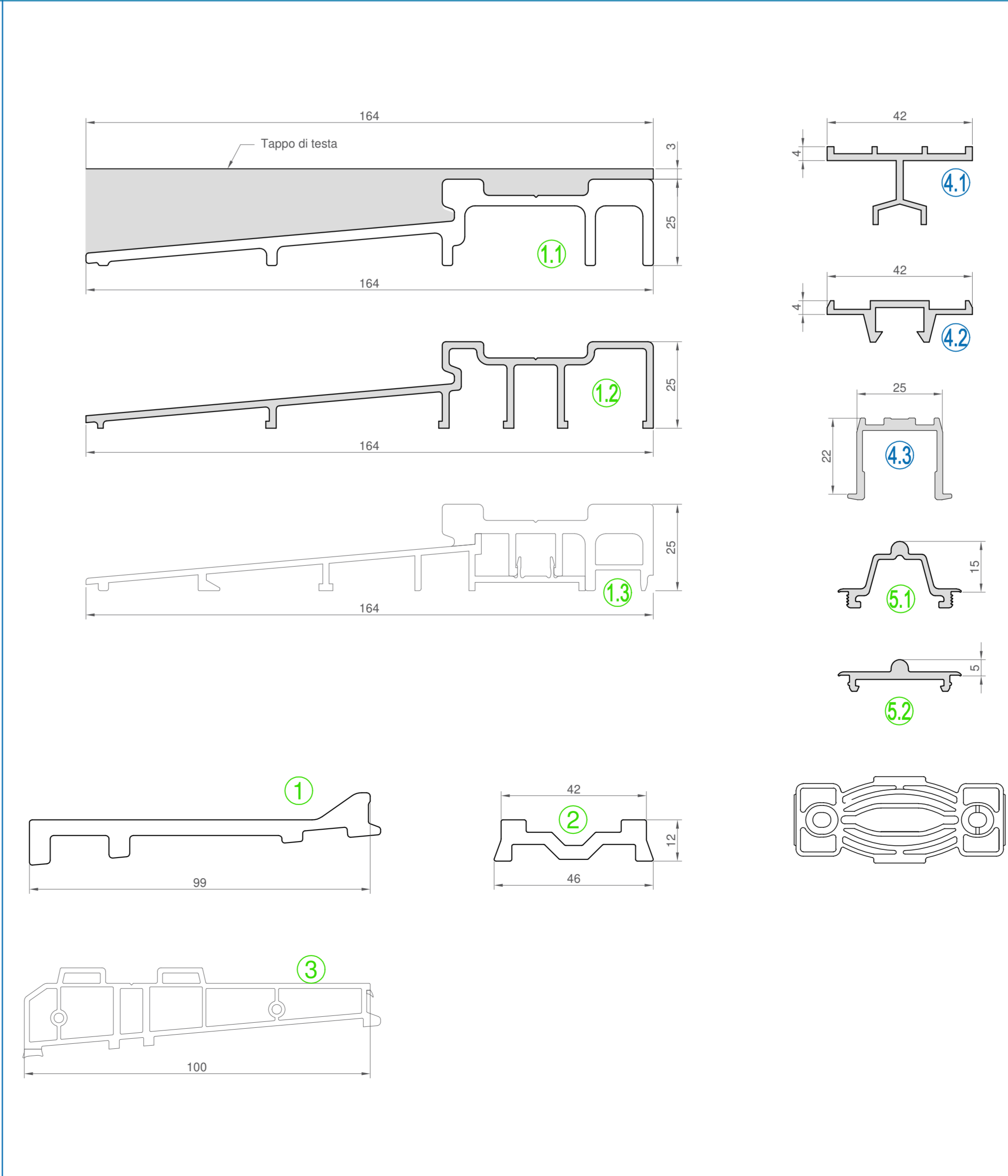

Listelli centrali

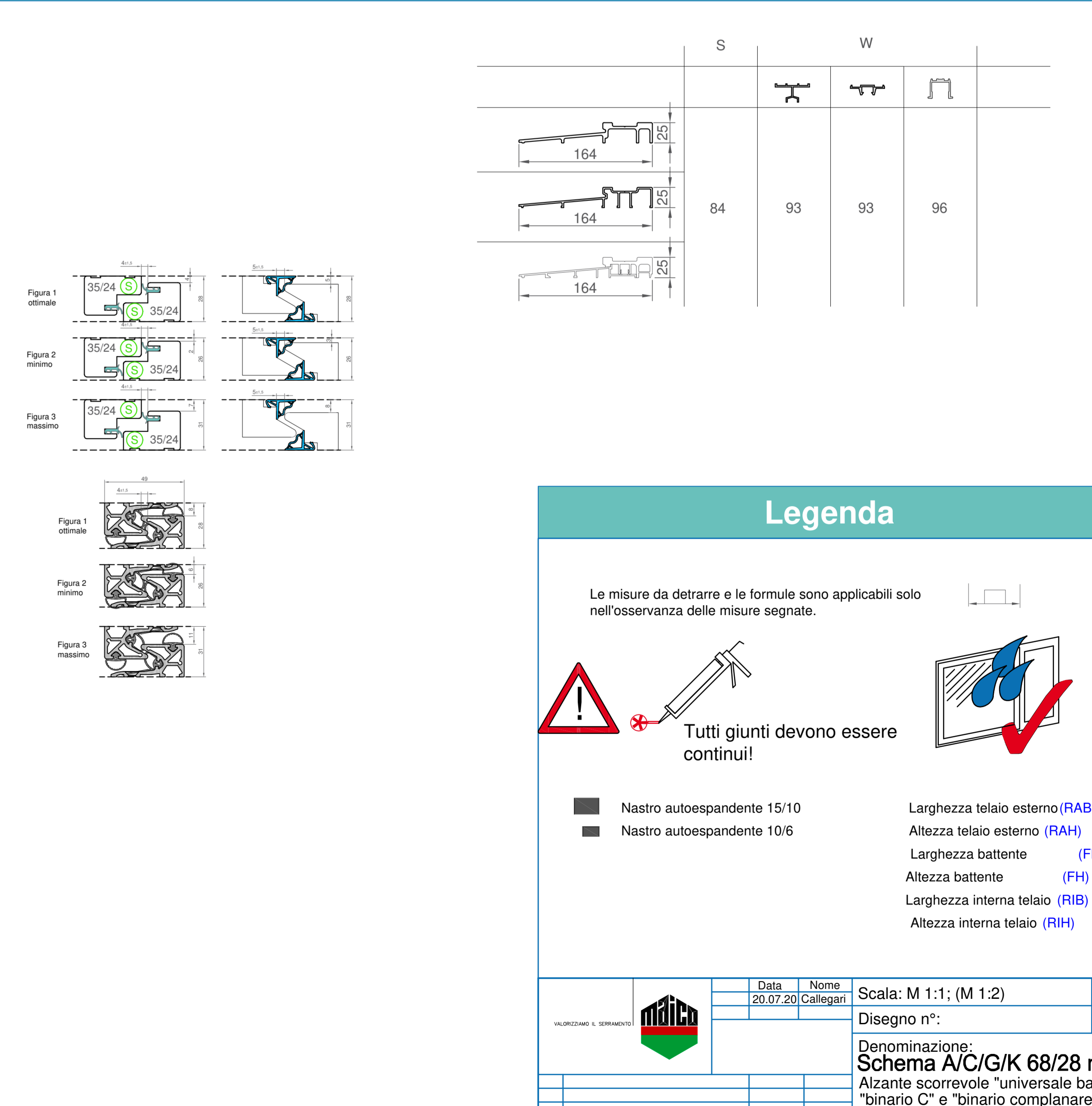

Procedura di montaggio soglia

Sezioni orizzontali Schema C, G, K (M 1 : 2)

1. Tagli  
 Profilo livellatore soglia  
 Profilo su soglia per area testa  
 Binario di scorrimento

Schema A	x = 84	Schema A	x = 94
Schema C	x = 84	Schema C	x = 94
Schema G	x = 84	Schema G	x = 94
Schema K	x = 177	Schema K	x = 170
	z = 0		z = 34

