

Sezioni battenti M 1:1

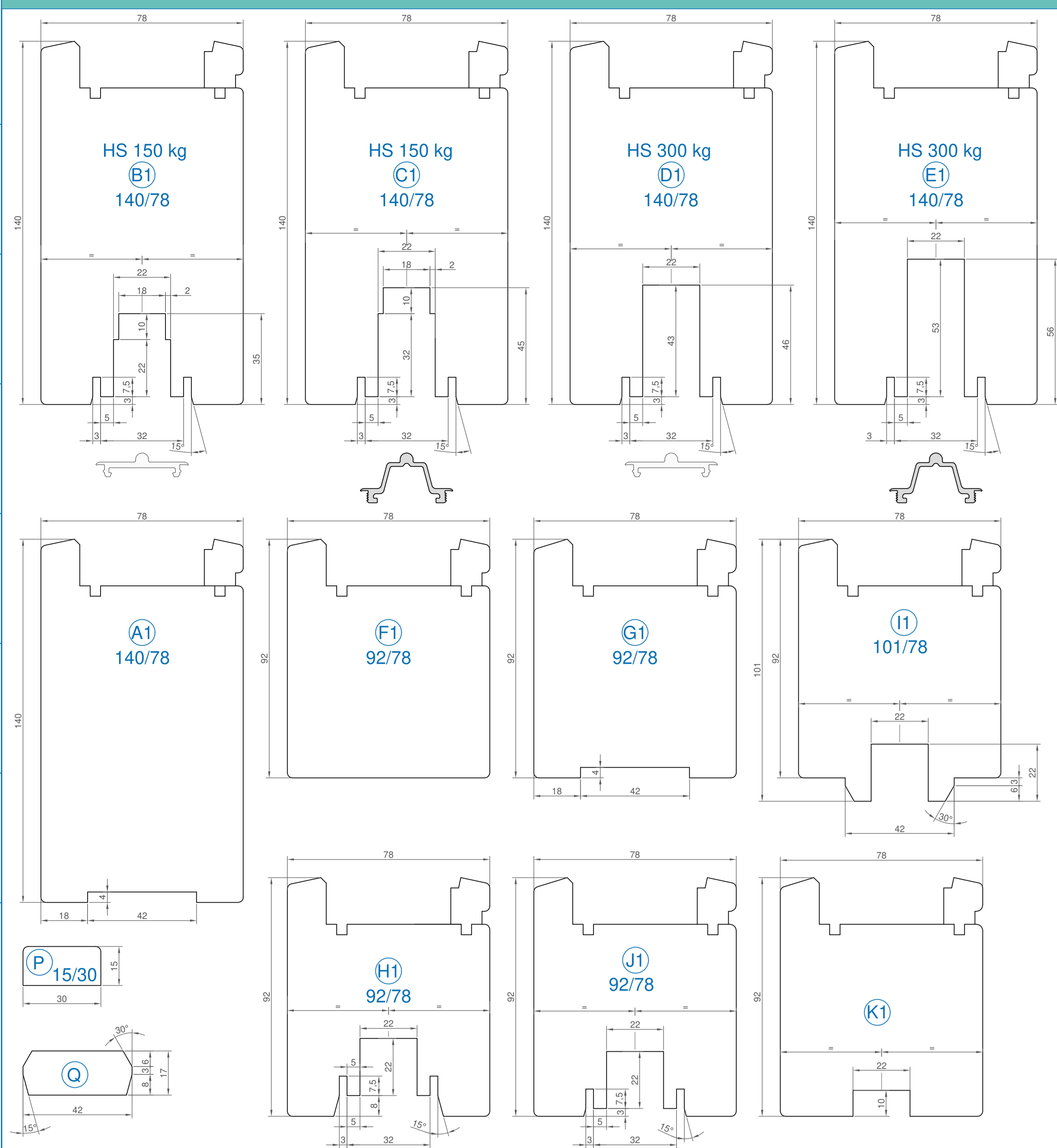

Sezioni Schema A M 1:2

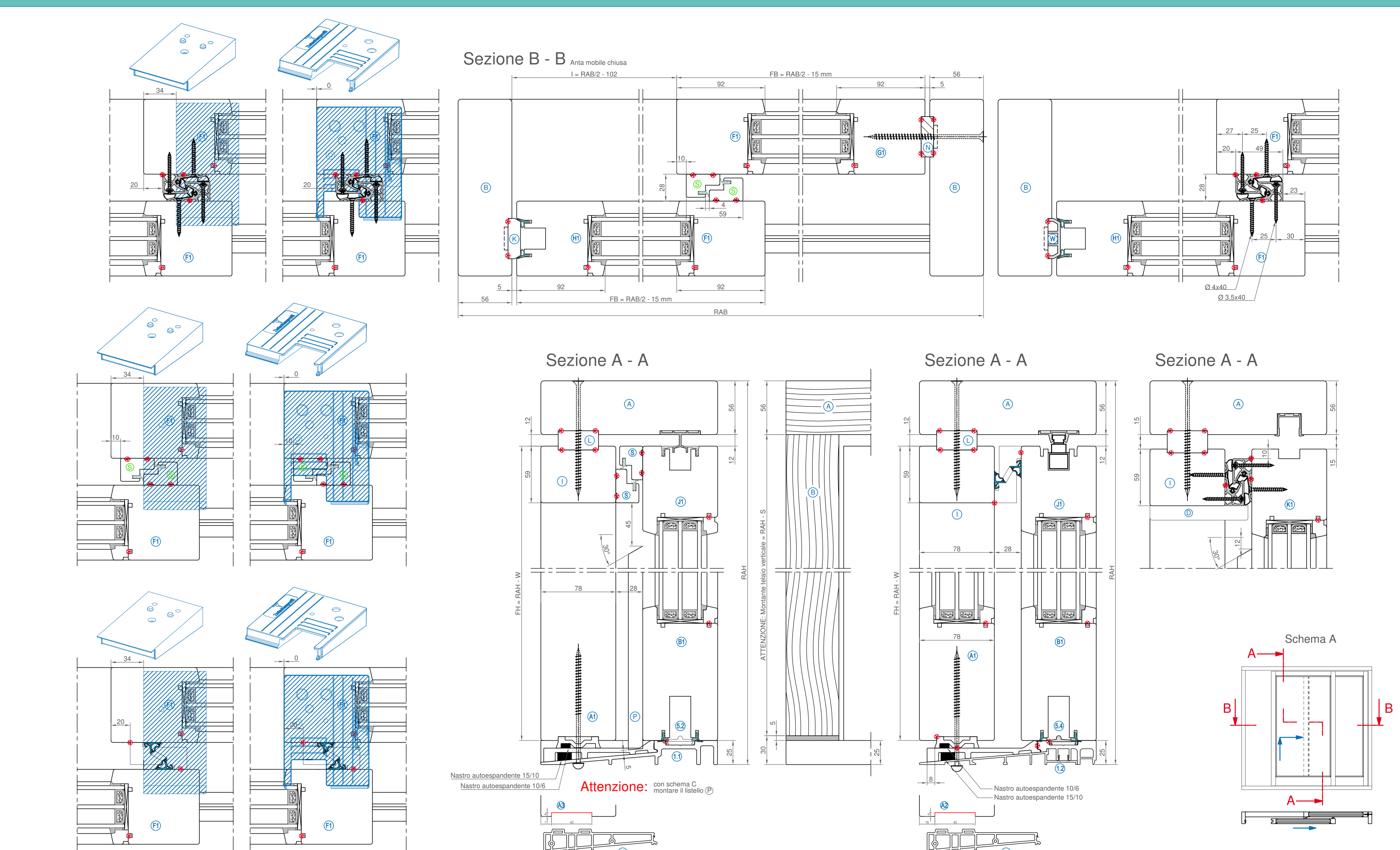

Sezioni telaio M 1:1

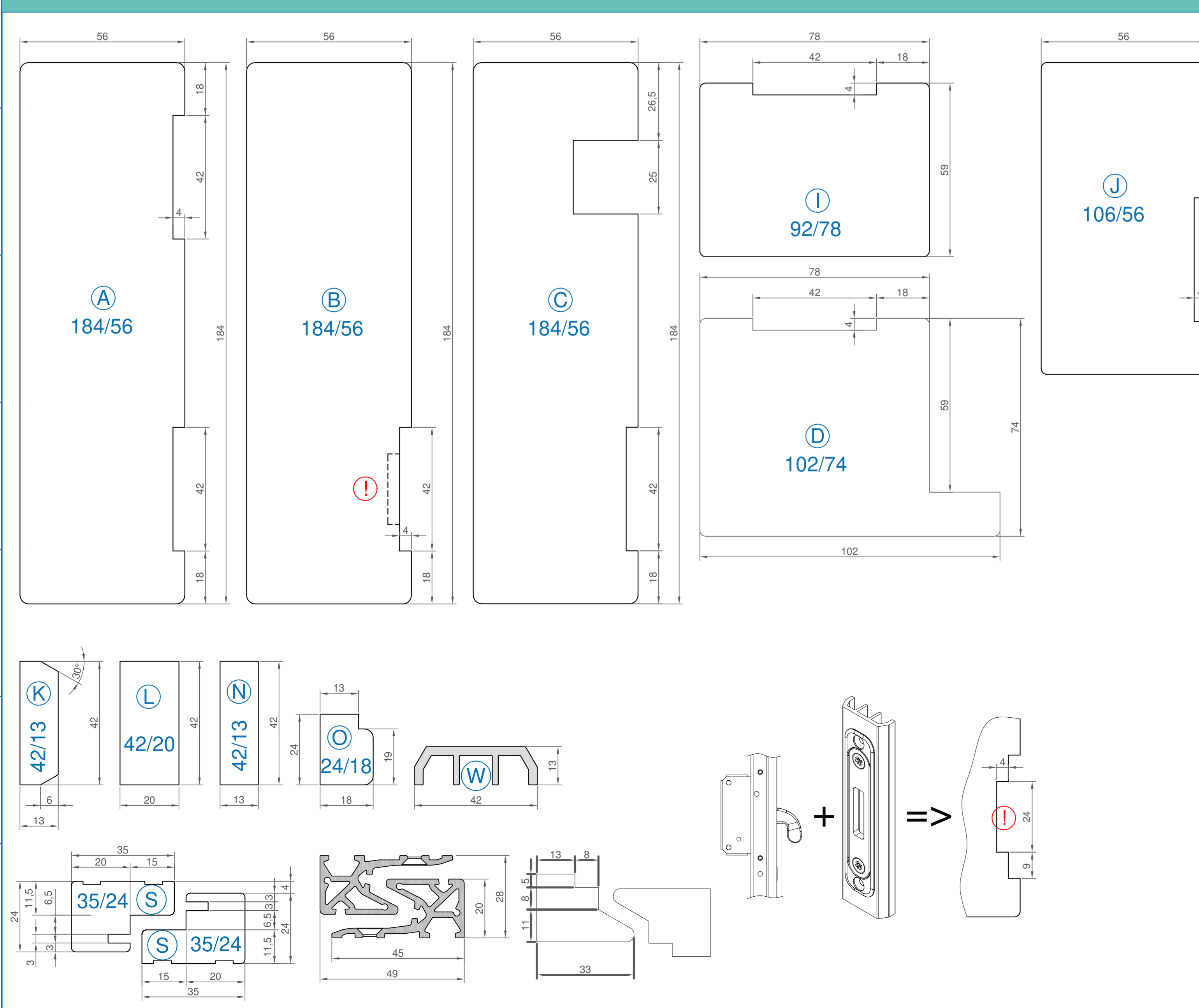

Particolari telaio M 1:1

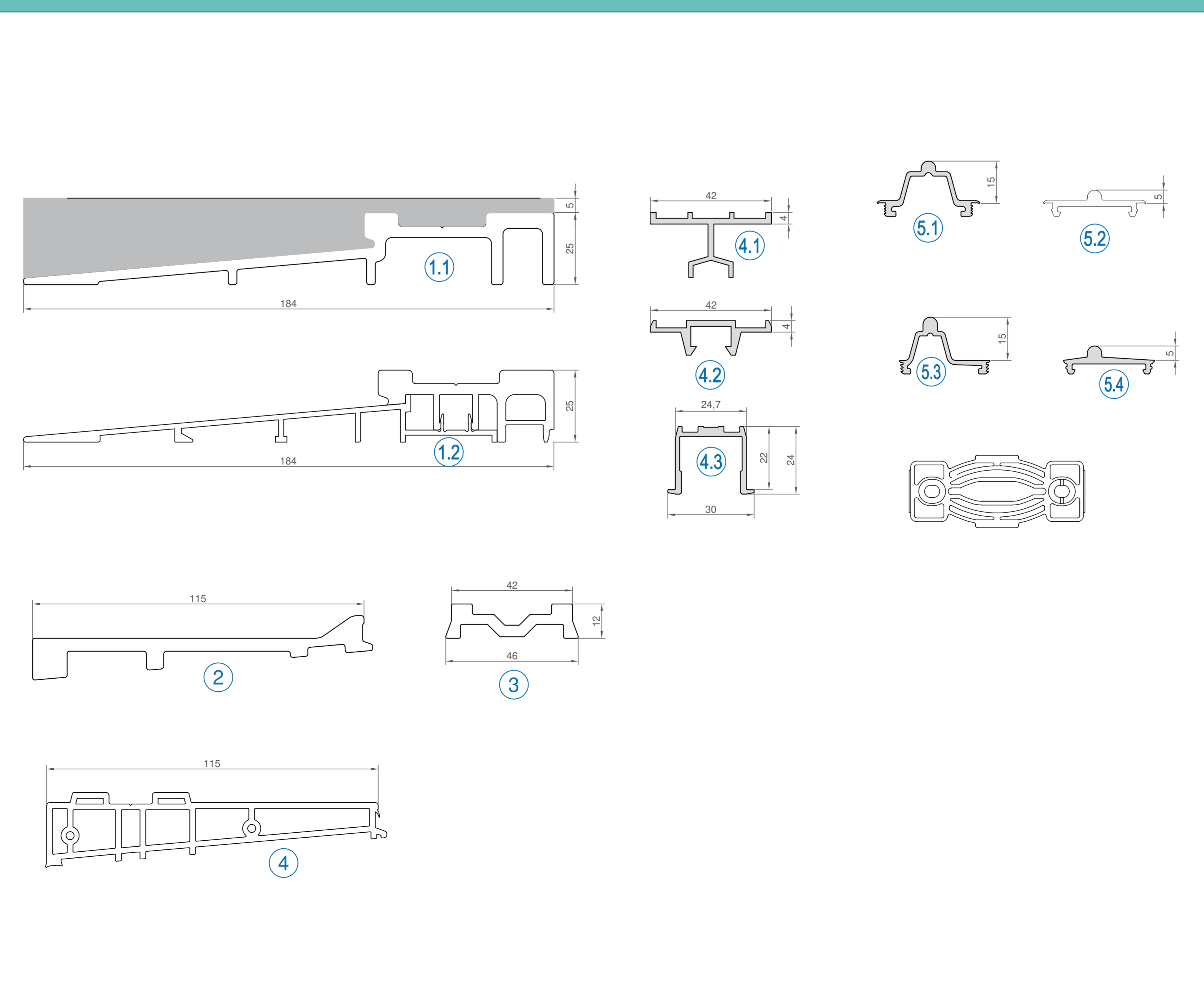

Listelli centrali

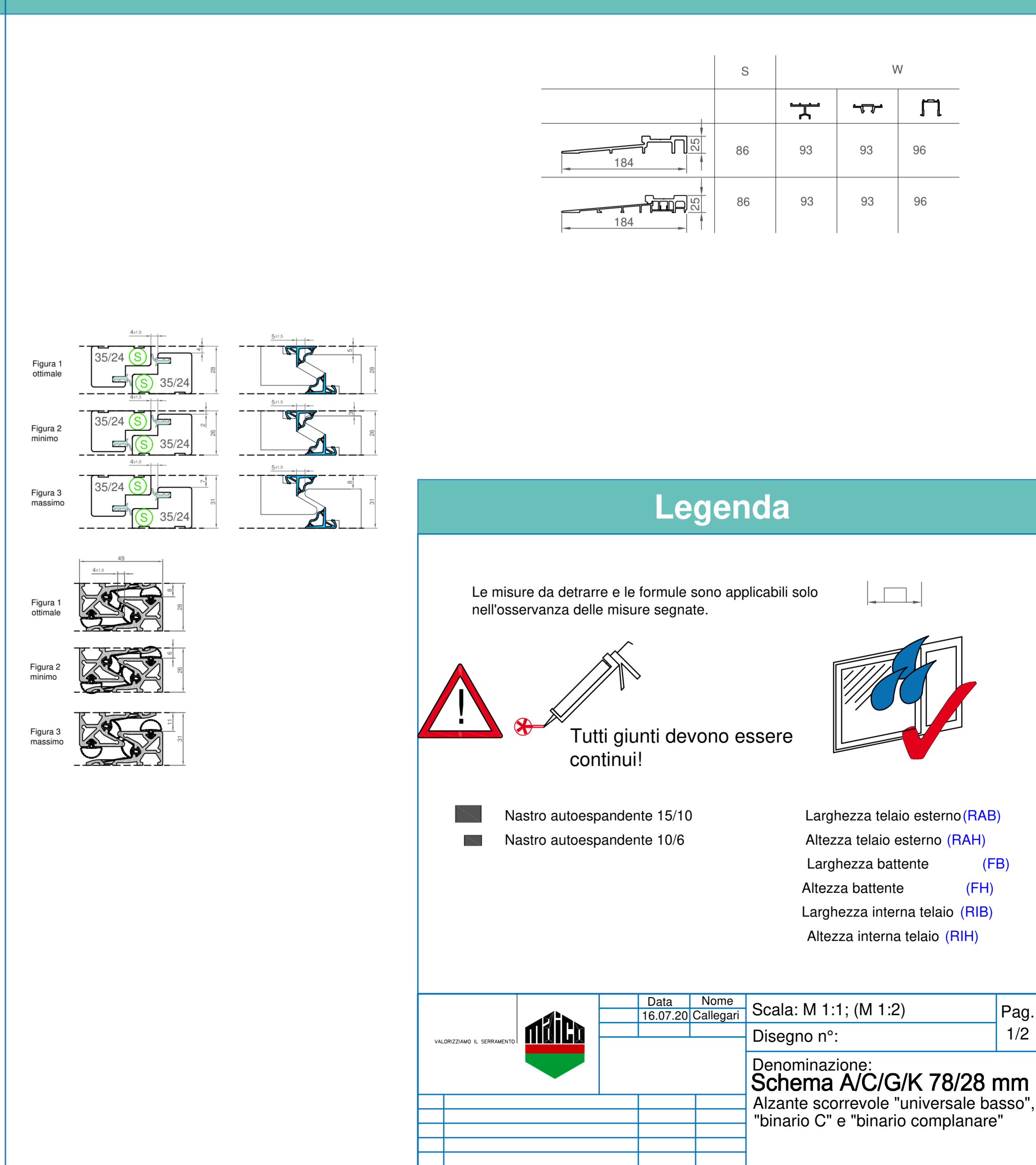

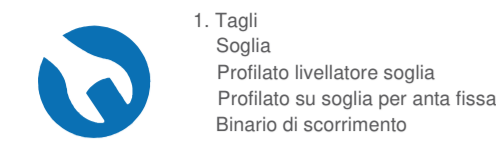

1. Tagli
Soglia
Profilato livellatore soglia
Binario di scorrimento

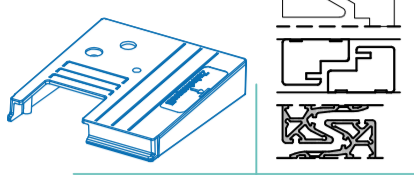

2. Binario di scorrimento basso
- Incassare con dritta 200223
- Inserire in cava e avvitare
- Spingere su alente di posizionamento
- Montare il binario

Schema A x = 84

Schema C x = 84

Schema G x = 84
y = 104

Schema K x = 177
y = 87

z = 0

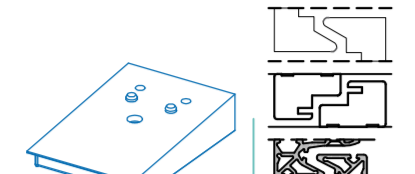

3. Forare soglia per tappo centrale art.302790

Schema A x = 94

Schema C x = 94

Schema G x = 94
y = 80

Schema K x = 170
y = 53

z = 34

Schema A

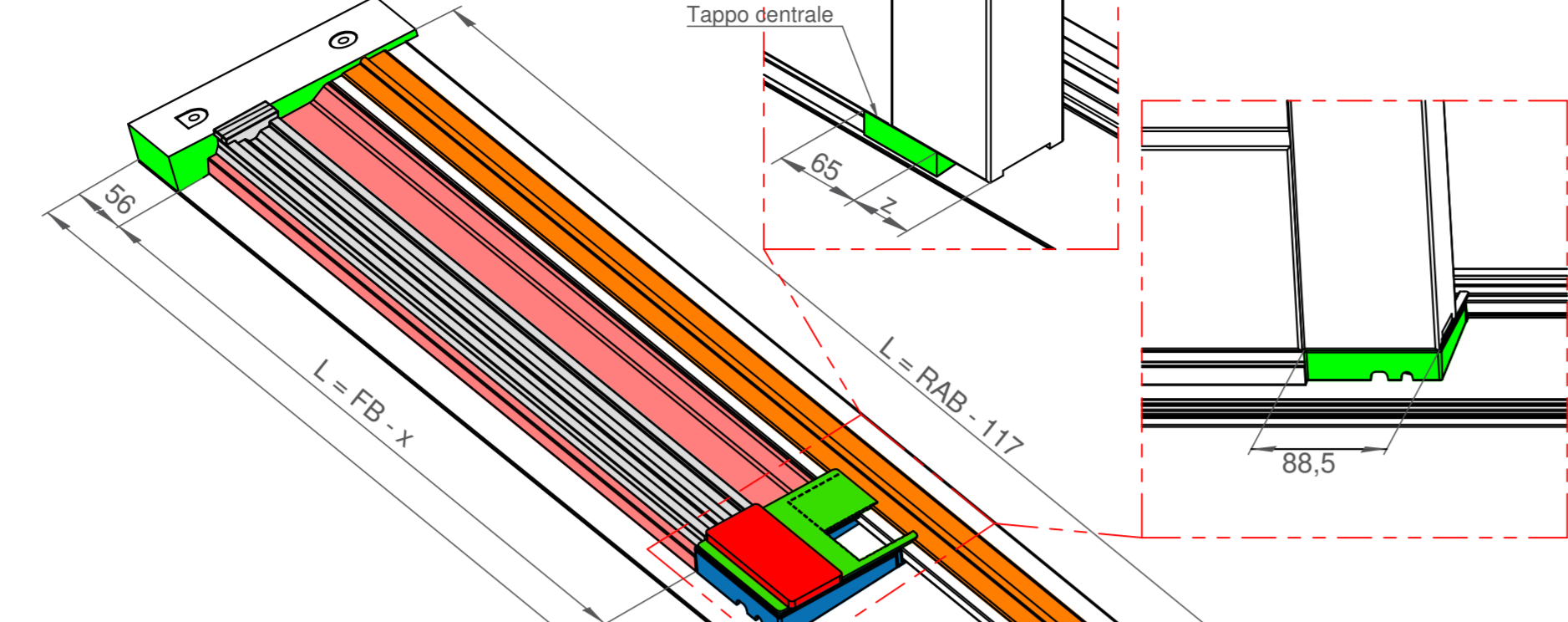

Schema C

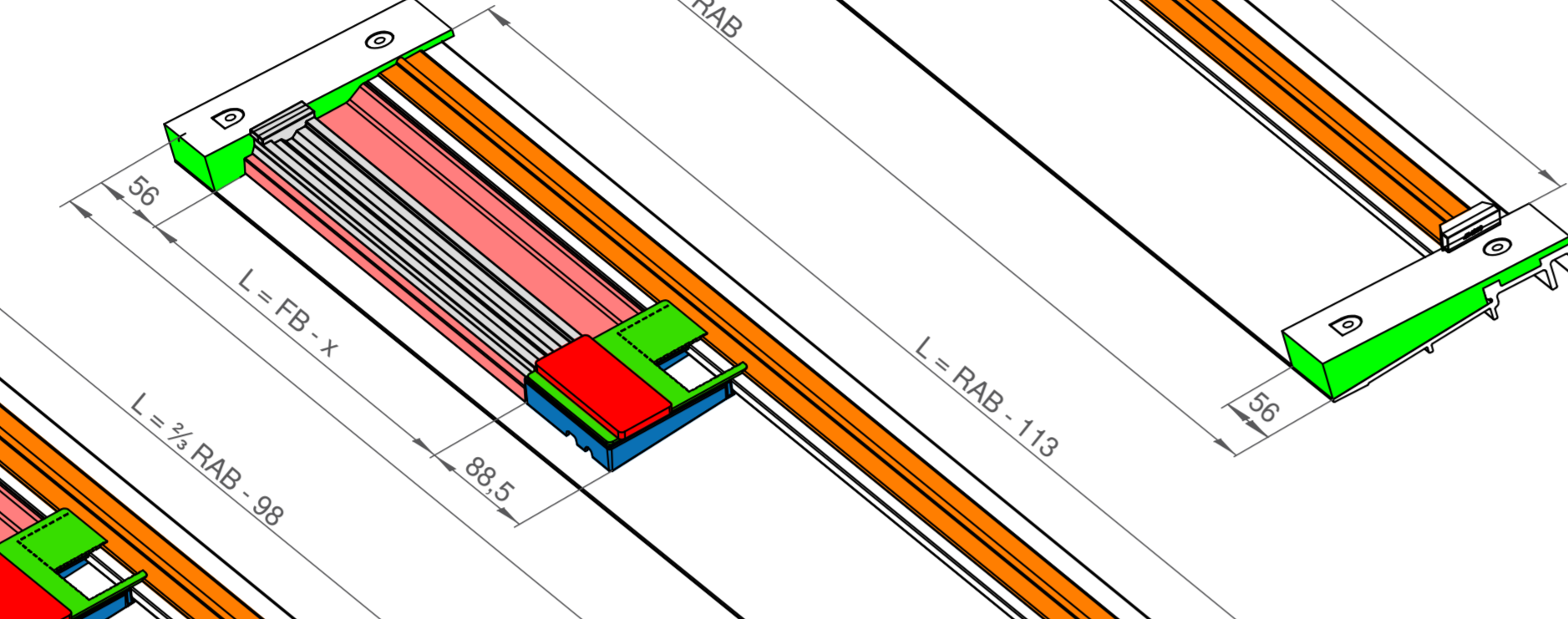

Schema G

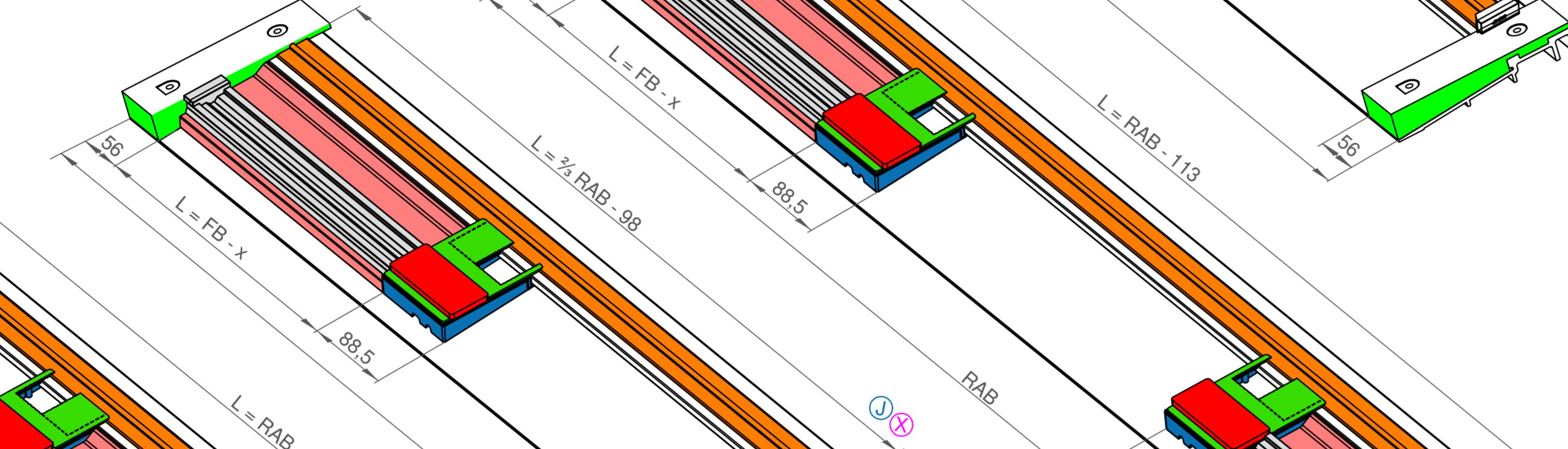

Schema K

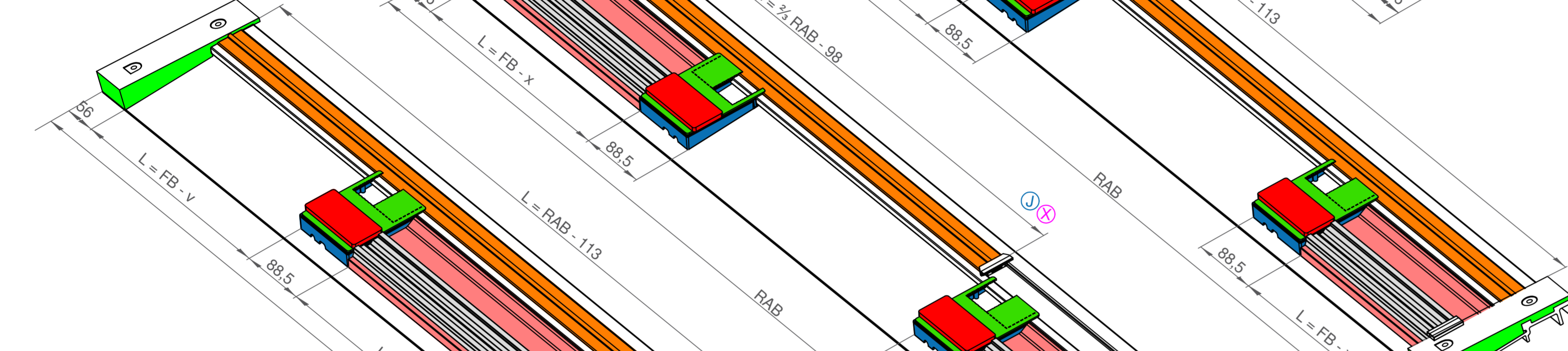

Variante 1 Fissaggio inferiore con viti

