



TECHNOLOGY IN MOTION

MACO RAIL-SYSTEMS

SLIDING HARDWARE



ASSEMBLY INSTRUCTIONS

HS COMFORT CLOSE / COMFORT STOP
concealed with reinforcement 1352543
Aluplast 85

Table of contents

Important instructions	3
<hr/>	
Function	3
<hr/>	
Fittings overview	4 - 5
<hr/>	
Preparation frame - Example: scheme A and C	6
<hr/>	
Preparation sash	7
<hr/>	
Mounting Comfort Close/Comfort Stop	8
<hr/>	
Mounting sash and frame	9
<hr/>	
Reference dimension	9
<hr/>	
Completion of guide track	10
<hr/>	
Adjustment options	10
<hr/>	
Mounting cover frame piece	11
<hr/>	
Technical data	11

Important instructions

Target group

This documentation is intended exclusively for specialist companies and certified specialists. The work described herein must only be carried out by certified specialists.

Usage and safety information

In addition to this information, the profile-dependent assembly instructions for HS-Hardware Aluplast 85, Order No. 756939EN, must be complied with. In the Comfort Close assembly instructions, only the differences from the above document are described. Mount all hardware parts professionally as described in this manual and observe all safety instructions.

Function

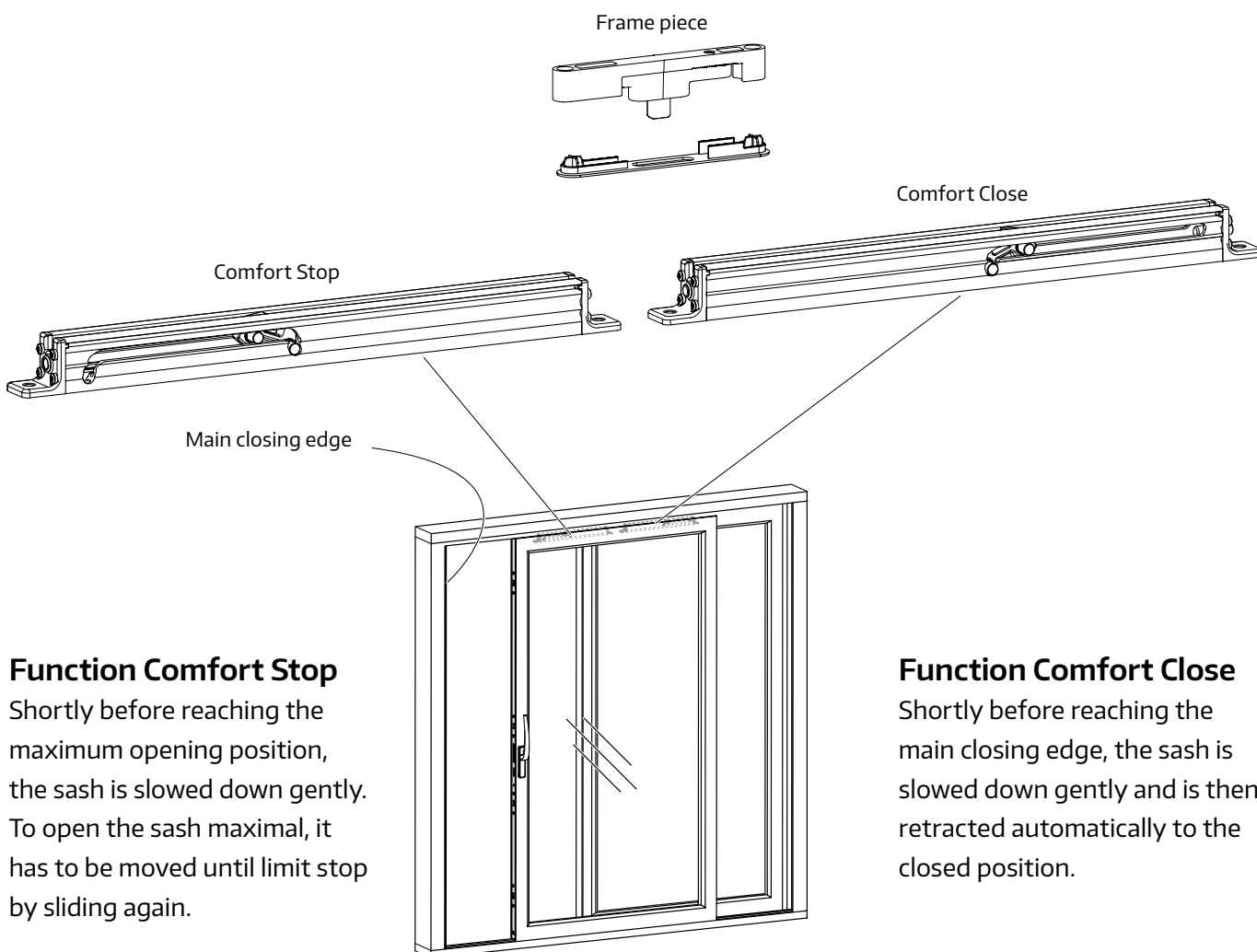

Fittings overview

Pos.	Description
4.24	Top guide
6.1	Guide Track
15.1	Comfort Close
15.2	Comfort Stop
16.1	Packer housing
16.2	Frame piece
16.3	Cover frame piece

Note: All measurements in this document are indicated in millimetres.

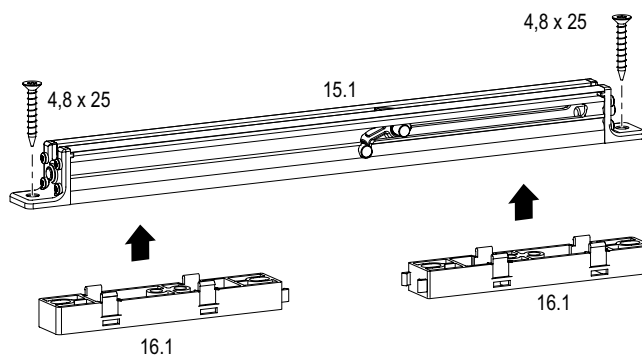
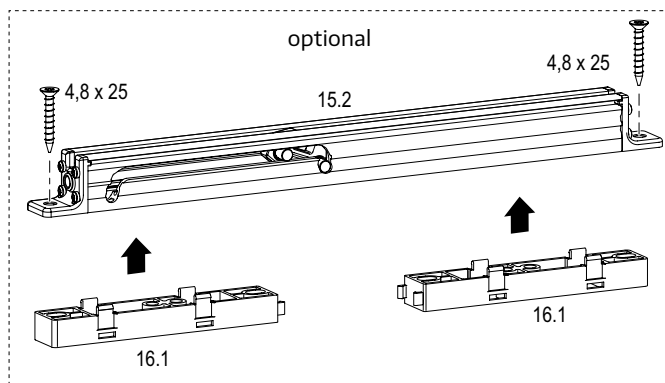
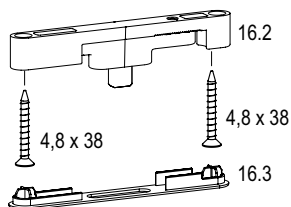

required for mounting:
guide track (please refer to
HS-mounting instructions Aluplast 85,
document item 756939en, too)

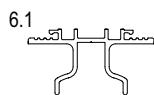

Guide track

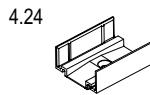

Top guide

Screws are not included in scope of
delivery.
Respective specifications represent a
recommendation, only.



Fittings overview

Items per sliding sash

	Article description		Item Code
1	Comfort Close 15.1 ²⁾	size 1 ≤ 200 kg sash weight ≤ 30 N sliding force	300359
		size 2 > 200 ... 300 kg sash weight ≤ 50 N sliding force	300360
1 ^{x)}	Comfort Stop 15.2 ²⁾	size 1 ≤ 200 kg sash weight ≤ 30 N sliding force	304052
		size 2 > 200 ... 300 kg sash weight ≤ 50 N sliding force	304053
	Accessories Comfort Close + Comfort Stop 16.1		305151
1	Accessories Comfort Close + Comfort Stop 16.1		305151
1	Frame piece, adjustable 16.2		305134
1	Cover frame piece 16.3		304816
1	Top guide Aluplast 85 for guide track Comfort Close 4.24		302681
1	Top guide HS Comfort Close Aluplast 85 L=3,500mm Silver 6.1		302023
	Top guide HS Comfort Close Aluplast 85 L=5,500mm Silver 6.1		302026
	Top guide HS Comfort Close Aluplast 85 L=6,500mm Silver 6.1		302028

^{x)} optional ²⁾ Colour of damper: size 1 - black, size 2 - silver-grey

Preparation frame - Example: scheme A and C

Scheme A

Frame width

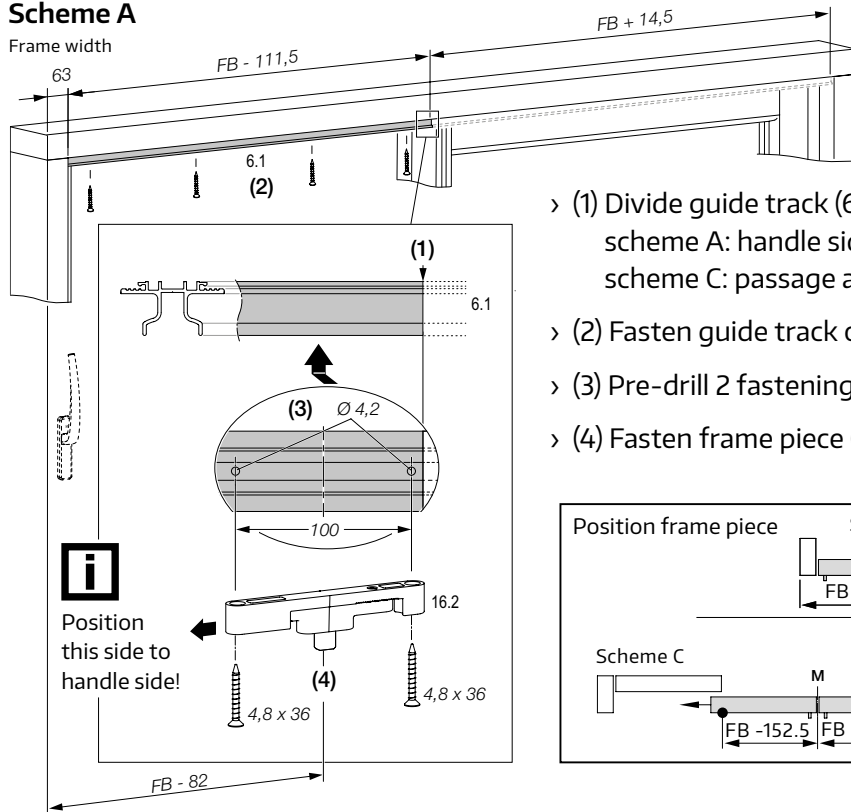
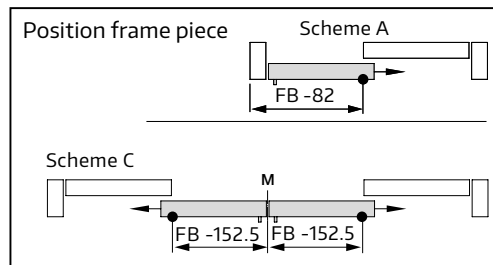

Illustration with dividing of the guide track; However, for this profile system dividing is not mandatory.

- > (1) Divide guide track (6.1):
 scheme A: handle side: $FB - 111.5$ mm, fixed sash side: $FB + 14.5$.
 scheme C: passage area: $2 \cdot FB - 185$, fixed sash: $FB + 14.5$.
- > (2) Fasten guide track on handle side.
- > (3) Pre-drill 2 fastening holes $\text{Ø } 4.2$.
- > (4) Fasten frame piece (16.2).



Scheme C

Frame width

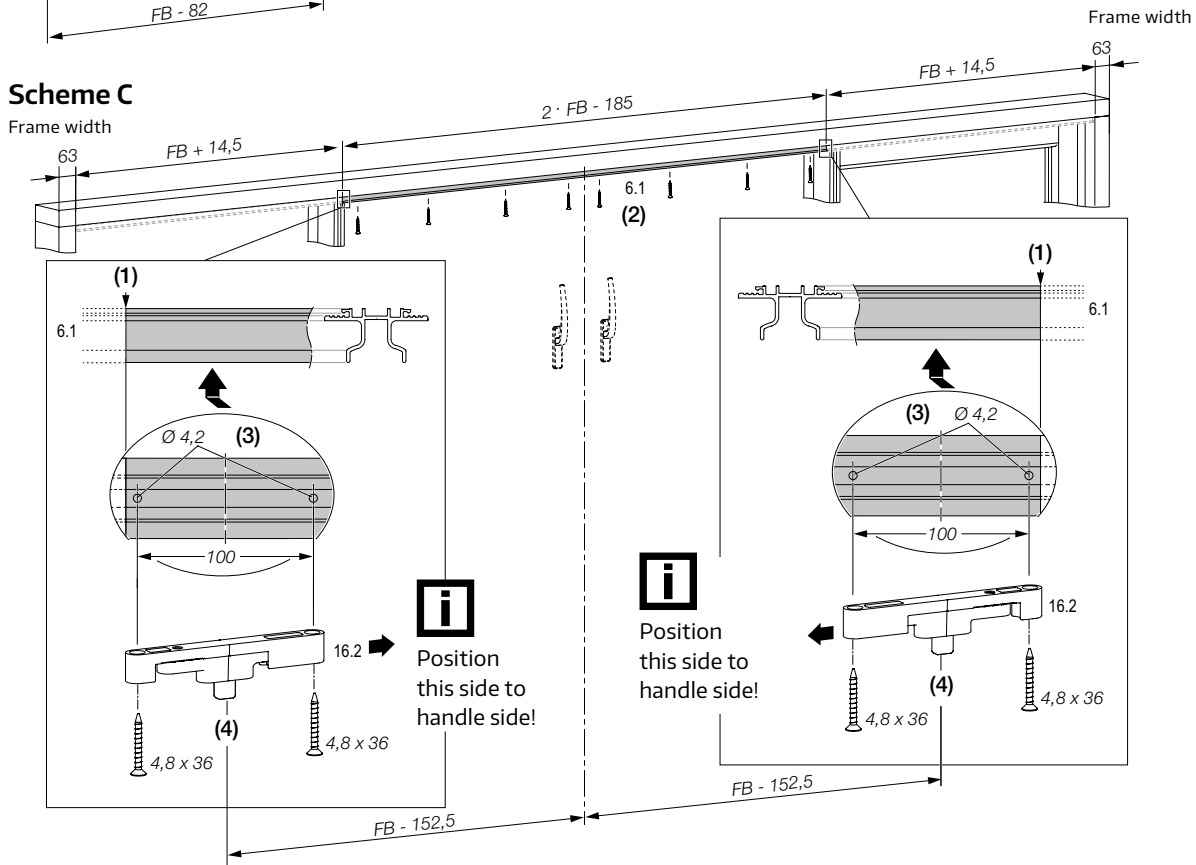

Frame width

Preparation sash

› Carry out sash milling for Comfort Close on non-handle side and/or for Comfort Stop on handle side.



The reinforcement „1352543“ has to be within the area of Comfort Close respectively Comfort Stop (slide in max. 108 mm to outer edge of sash).

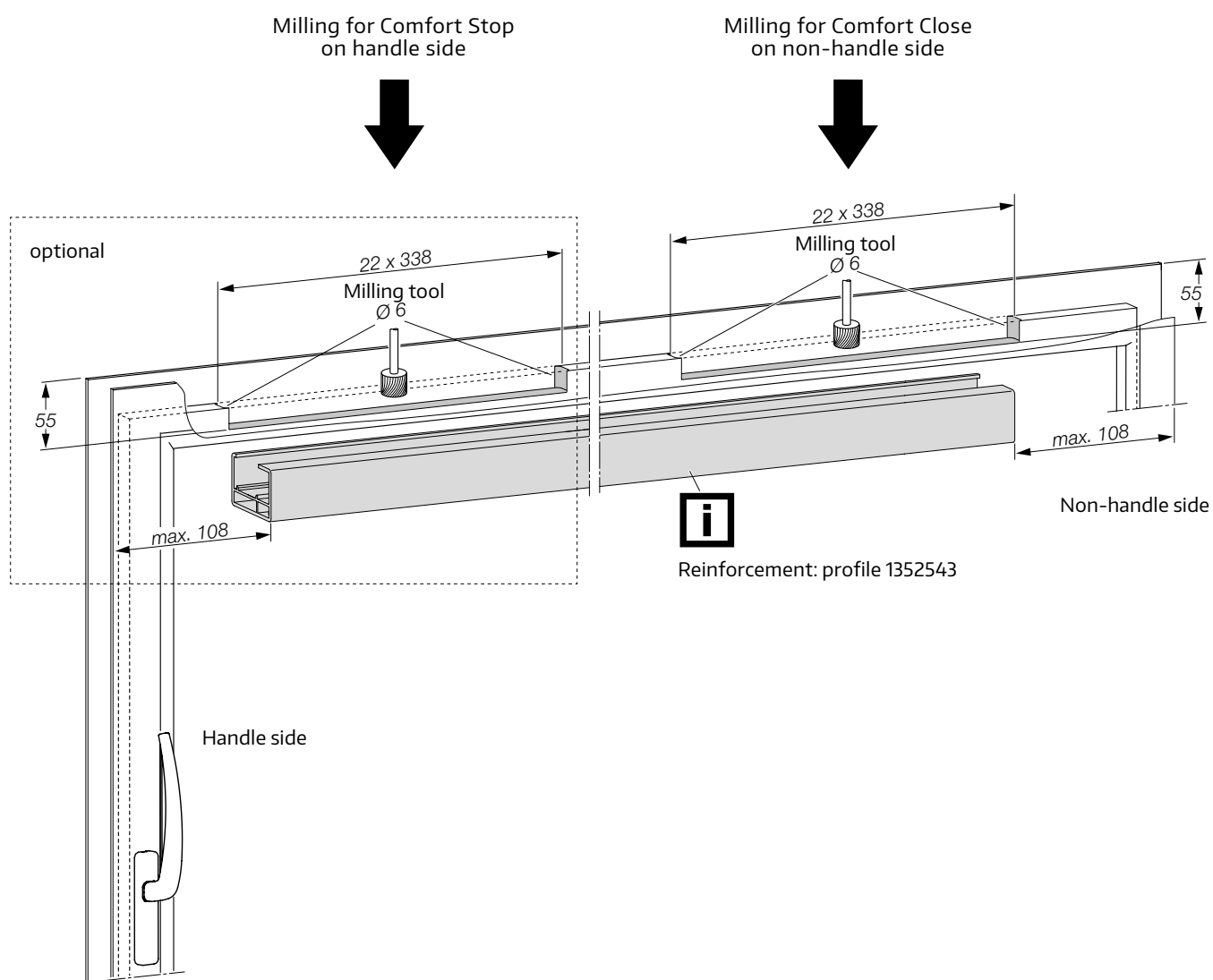

Mounting Comfort Close/Comfort Stop

- > (1) Comfort Close respectively Comfort Stop has to be pretensioned.
- > (2) Clip packer onto the housing of the Comfort Close and/or onto the housing of the Comfort Stop.
- > (3) Mount the Comfort Close respectively Comfort Stop with 2 screws 4.8 x 25 each at the sash.

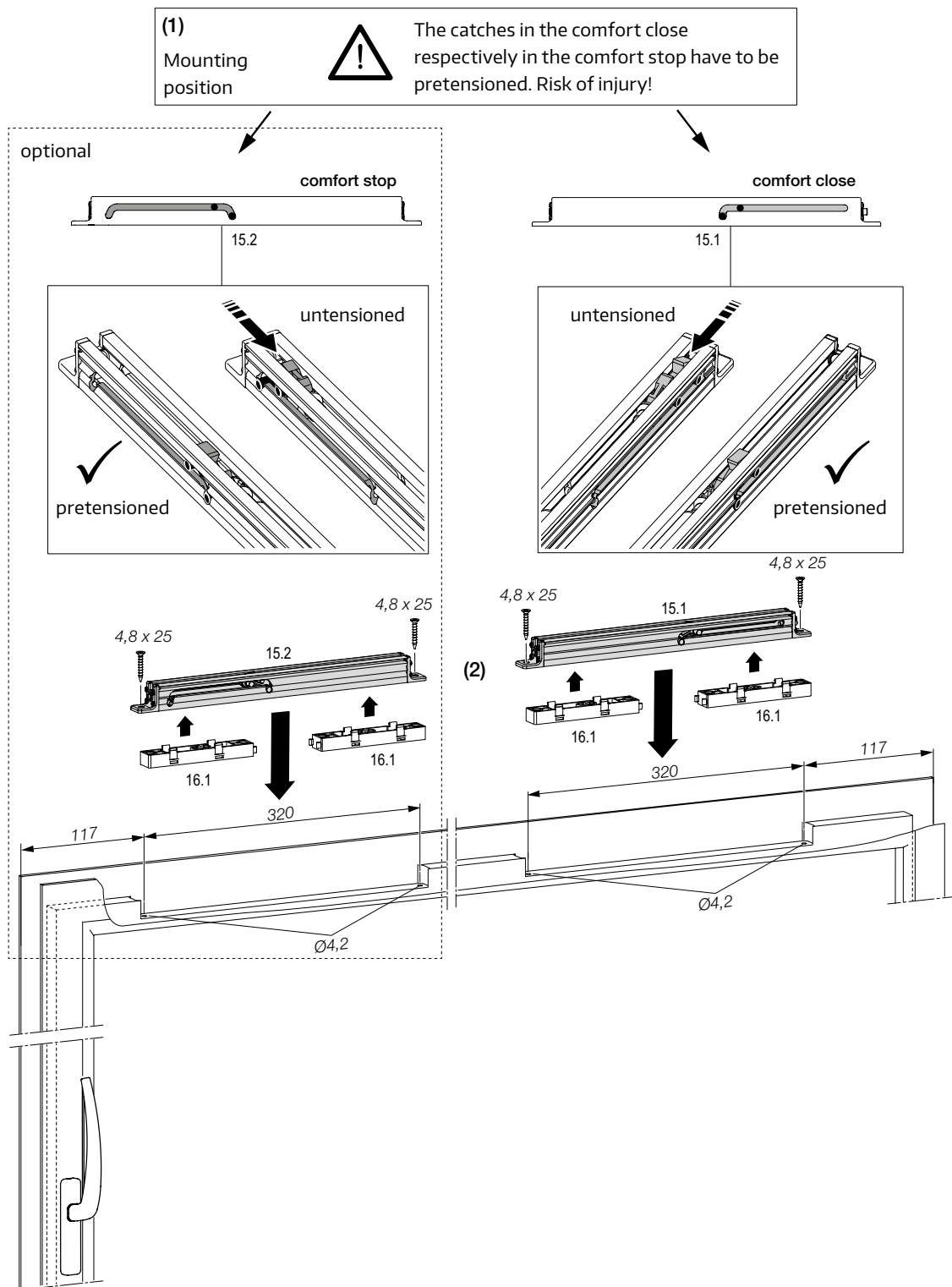

Mounting sash and frame



Attention: Risk of injury due to fallen sash!

To avoid the risk of injury, perform the following steps with two workers.

Example: scheme A; scheme C accordingly

- › (1) Set down the sliding sash onto the running track in the area of the fixed sash and swivel it into the element.
- › (2) Bring handle into „Open“ position and slide the sliding sash to the transit area.

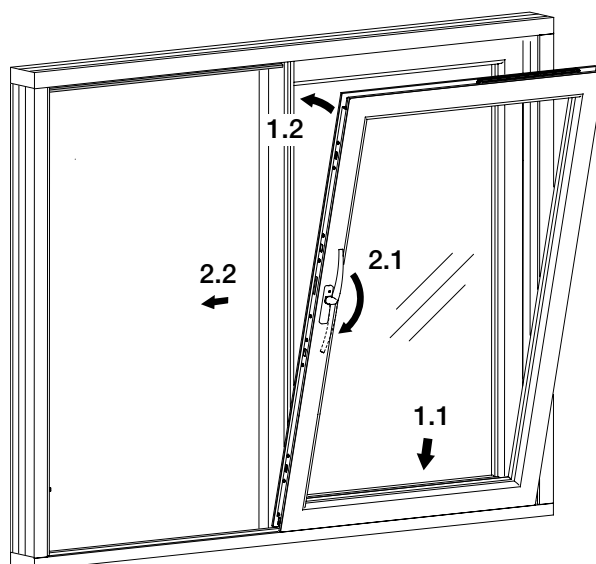

Reference dimension

- › To check the height of the frame piece, swivel in the sash, lift it and slide into closing position.
- › Measure reference dimension within the range of the comfort close respectively comfort stop (desired value = 9 mm).
- › If necessary, slide the sash aside and compensate deviation to the reference dimension by adjustment of the frame piece (refer to „Adjustment options“).
- › Fasten guide track on fixed sash side.

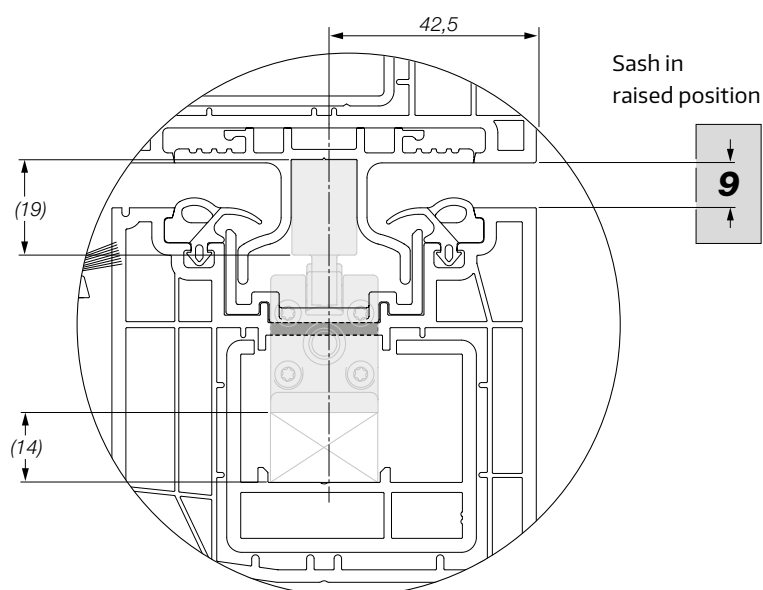

Completion of guide track

(If the guide track is not divided, this work step is not necessary.)

Example:

scheme A; scheme C accordingly

Fasten the guide track at frame profile.

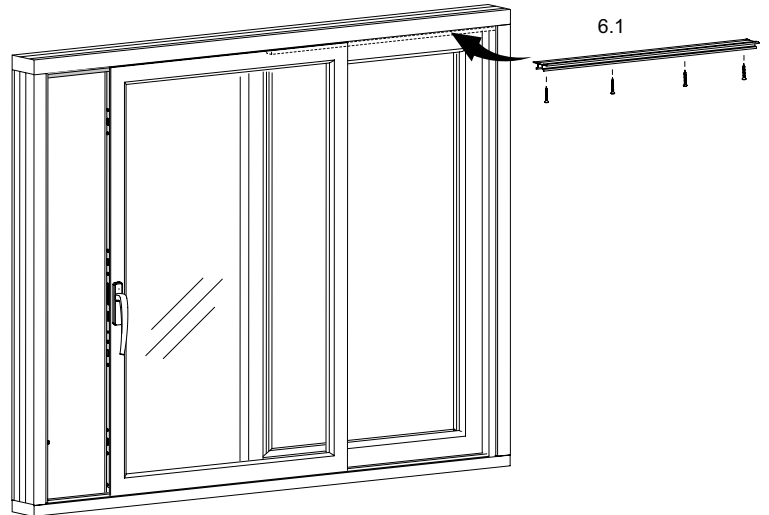

Adjustment options

In case of inaccuracy concerning position of the frame piece, the reference dimension concerning the height of the frame piece and the end position of the sash related to the frame can be adjusted.

To do this, the sash has to be opened.

- > (1) Correction of the lateral position (+/- 5 mm):
 - (1.1) Loosen screw by means of Torx 25,
 - (1.2) Slide frame piece into the desired direction:
 - 0 – 5 mm: closing of sash will be shifted in direction of handle side;
 - 0 + 5 mm: closing of sash will be shifted in direction of non-handle side
 - (1.3) Fasten screw with max. 3 Nm.
- > (2) Correction of the height of the frame piece (+ 3 mm) with Torx 15.

Adjustment at closing edge

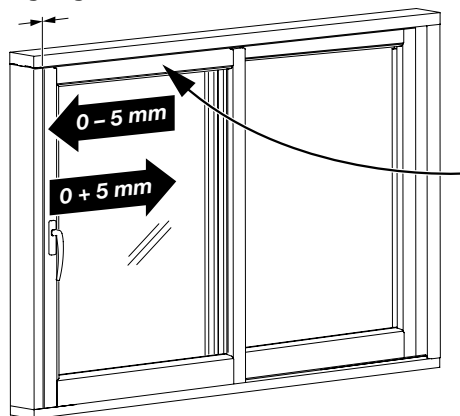

(Sash opened)

0 – 5 mm: towards closing position (frame)
0 + 5 mm: off the closing position (frame)

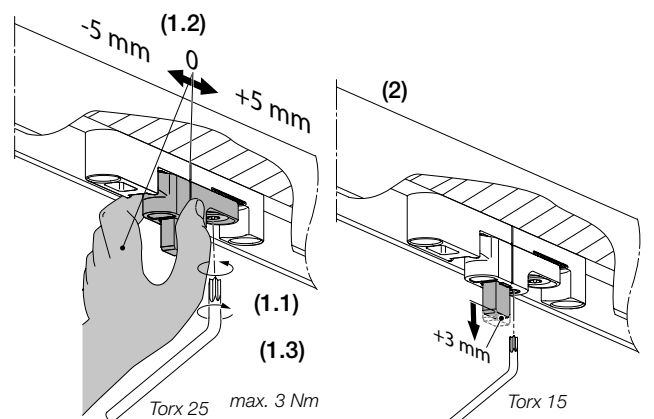

Note: Adjustments may be changed after glazing the sash and mounting the frame!

Mounting cover frame piece

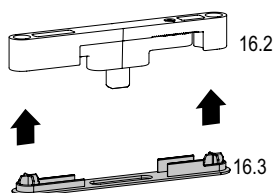

Technical data

Range of application scheme A:

Sash width (FB)	720 – 3235 mm
FB _{min.} for 2x Comfort Close	1000 mm
Sash height (FH)	1200 - 2700 mm
Outer frame width (RAB)	acc. to profile manufacturer's specifications
Sash weight or sliding force without Comfort Close and Comfort Stop	size 1: max. 200 kg or max. 30 N size 2: max. 300 kg or max. 50 N (further sizes on request)

Depending on version of the profile sealing to be used, it can happen, that the sash cannot close completely.

Dimensions (W x H x D)	
Comfort Close	336 mm x 27.5 mm x 22 mm
Comfort Stop	336 mm x 27.5 mm x 22 mm
Soft move-in	starting approx. 100 mm off the closing edge
Increase of sliding force with Comfort Close or Comfort Stop	size 1: by 25 N (black) size 2: by 45 N (silver-grey)

Range of application is depending on used profile systems. Specifications of profile manufacturers to be observed.

You want everything from a single source?

We provide you with complete solutions for sliding doors, windows and doors – for timber, PVC and aluminium. Experience our versatile system offer, comprehensive service included. Discover more of this on our website www.maco.eu or contact your MACO representative.

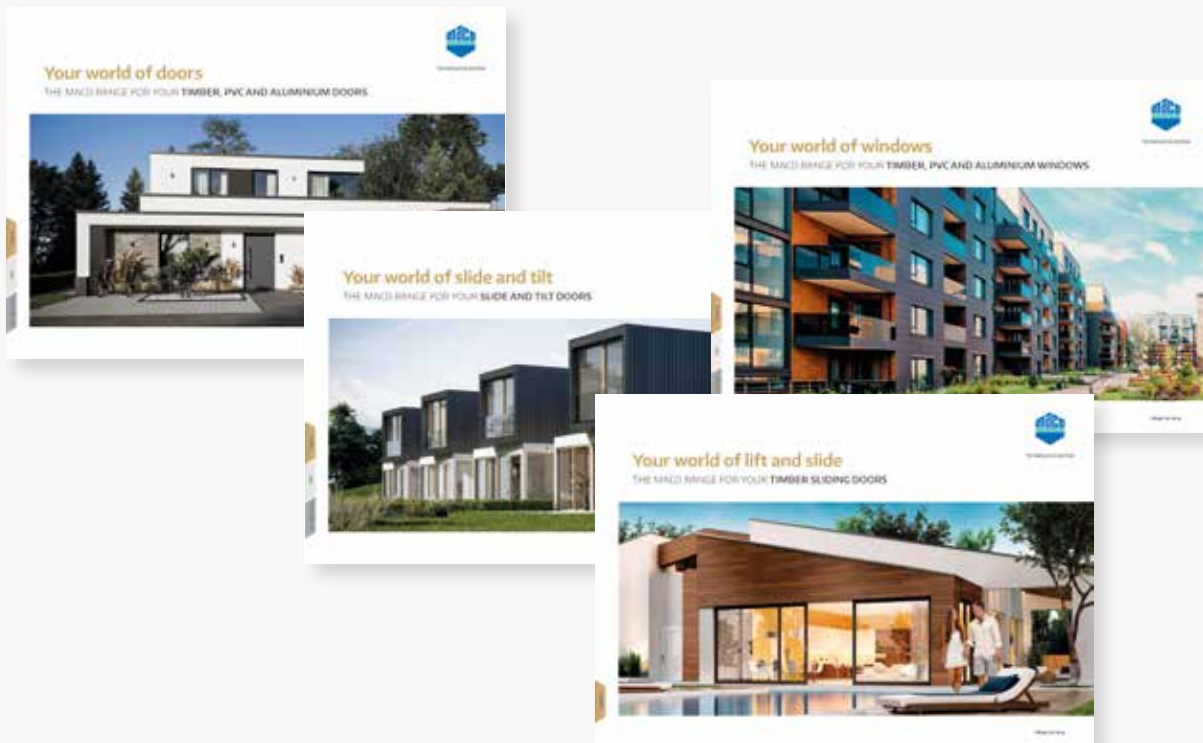

MACO near you:
www.maco.eu/contact



TECHNOLOGY IN MOTION



This print document is revised regularly.
The latest version is available at <http://www.maco.eu/assets/757739>
or by scanning the QR code.

Created: 01/2019 - Changed: 12.06.2020
Order no. 757739
All rights reserved and subject to change.