

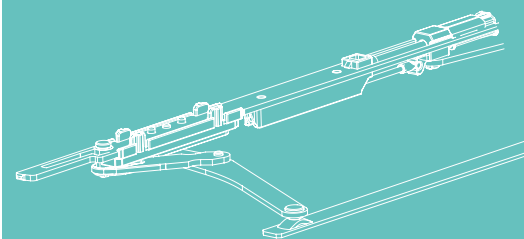

TECHNOLOGY IN MOTION

# MACO RAIL-SYSTEMS

SLIDE HARDWARE

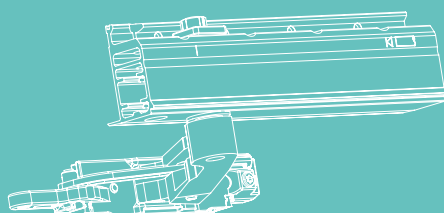
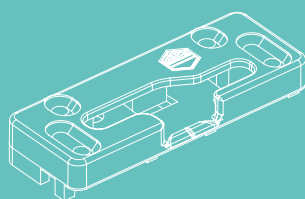

## ASSEMBLY INSTRUCTIONS

Timber / PVC 12 Air Parallel Stop-Slide Hardware

### Additional Instructions

- Sash weight > 160 kg
- Sash rebate width > 1650 mm
- Sash rebate height > 2450 mm

**Exclusively for use by specialist companies!**

## Table of contents

<b>Version and scope of application</b>	<b>3 - 4</b>
<hr/>	
<b>Sash Assembly</b>	<b>5</b>
Cutting to length and Central Locking assembly	5
<hr/>	
<b>Frame assembly</b>	<b>6 - 7</b>
Striker plate assembly	6
Strike plate assembly Scheme C	7
<hr/>	
<b>Sash Assembly</b>	<b>8 - 9</b>
Roller FG 200 kg assembly	8
Horizontal alignment of the sash	9

## Version and Application Areas

### Version

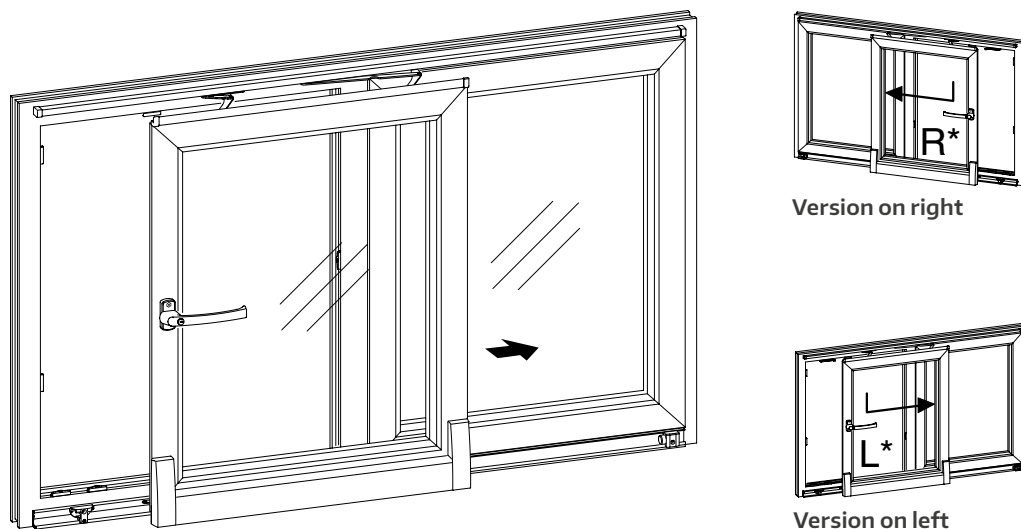

The illustrations in this document show the version on the left.

In order to install the version on the right, the applied information must be mirrored.

#### Note:

This document is only valid in conjunction with the assembly instructions for Parallel Stop-Slide Hardware, Order Number 759599.

In this manual only the deviating work steps are described, which are necessary for the assembly of a window element with sash weight > 160 kg (SW min. 1250 mm) and/or SRH > 2350 mm, SRW > 1650 mm.

### Area of application Parallel Stop-Slide Hardware

The limits of the areas of application listed here are binding and must not be deviated from. Continue to observe the permissible application sizes, manufacturing specifications, and fabrication policies as set by the profile manufacturer.

Description	Unit	Area
Sash rebate width (SRW)	(mm)	1651 - 2000
Sash rebate height (SRH)	(mm)	2451 - 2685
Sash weight	(kg)	max. 200
Burglary prevention		possible

# Version and Application Areas

## Application Diagram

### Application 200 kg

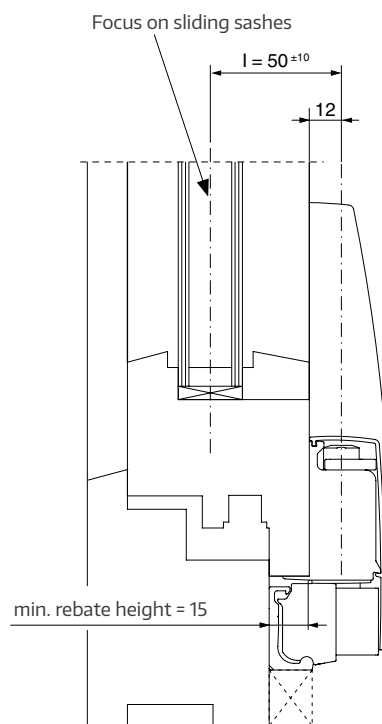
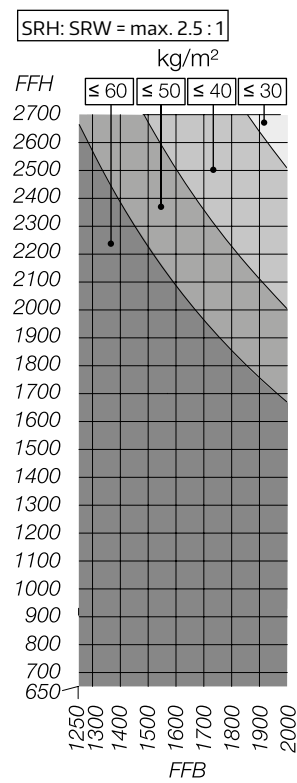

valid for an I-value of  $50^{-10}$

## Mounting screws for the hardware components

These are not included. The length must be selected according to the profiles used.

Countersunk screws 4,0 x ... mm

Countersunk screws 4,0 x ... mm, **Important:** head diameter  $d_k$  7 mm

Countersunk screws 4,8 x ... mm

## Cutting to length and Central Locking assembly

- A Screw on the corner element MM with 2 i.S. ① and corner element MM vertically extendable with toothed box with 1 i.S. ②.
- B Screw on the centre lock extendable MM 1280 V ③.
- C Cut the upper and lower width connector ④ to length and screw on.
- D Screw on the faceplate extension MM 235 ⑤.
- E Shorten the rotary drive MM 2250 variable ⑥ and screw it on in the middle.
- F Cut the height connector MM 2450 ⑦ to length and screw it on.

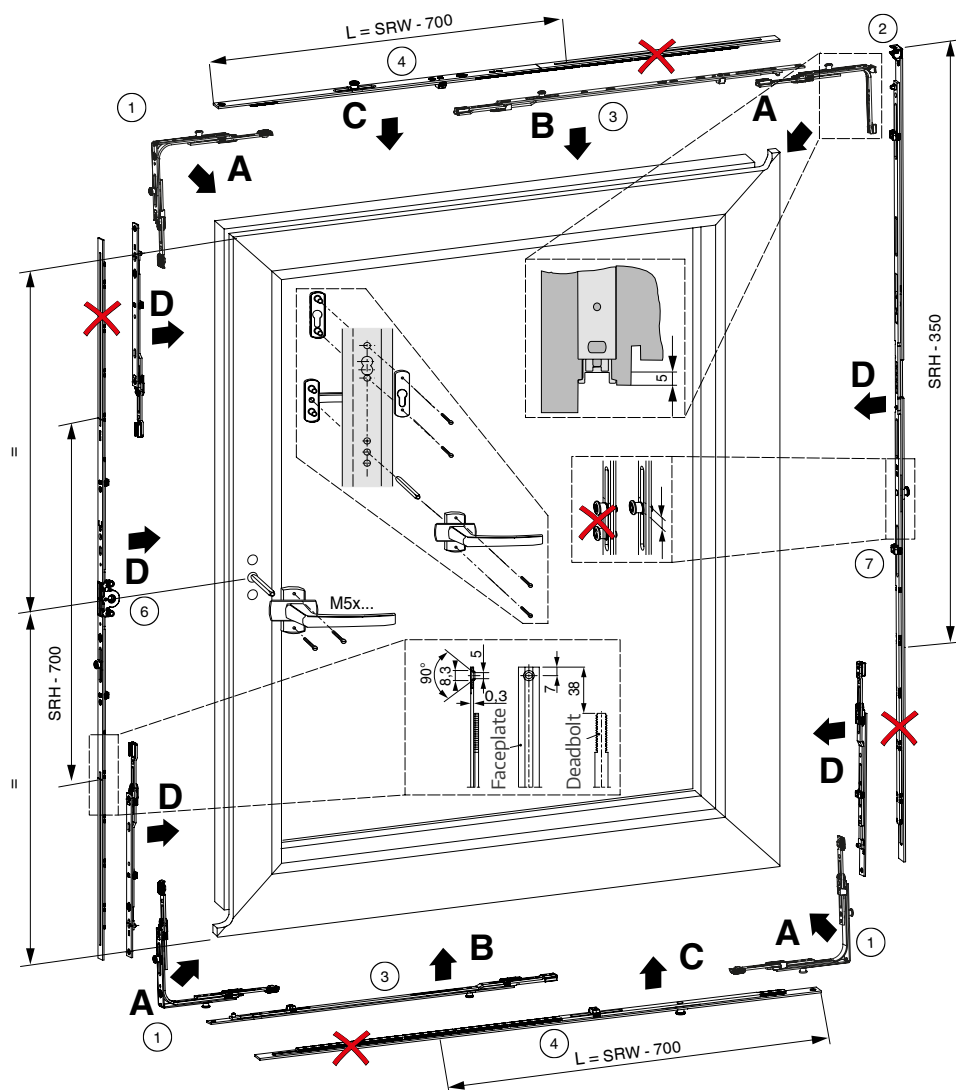
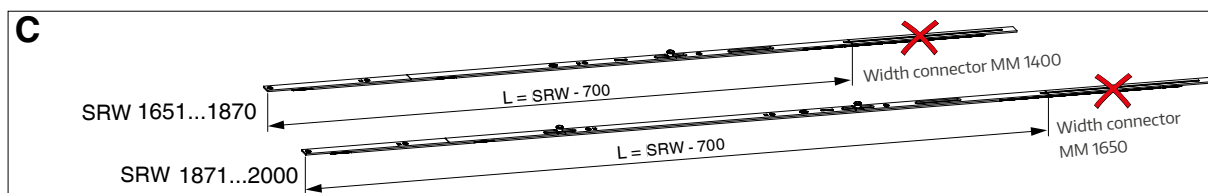

# Frame assembly

## Striker plates assembly

SRW: 1651 - 2000

SRH: 2451 - 2685

Position and fasten the night ventilation striker plate PAS <sup>9</sup> and striker plate <sup>10</sup> according to the illustration.



Use:

Fitting screw 4,0 x ... d<sub>k</sub> 7 mm

All dimensions given are valid for a rebate gap of 12 mm.

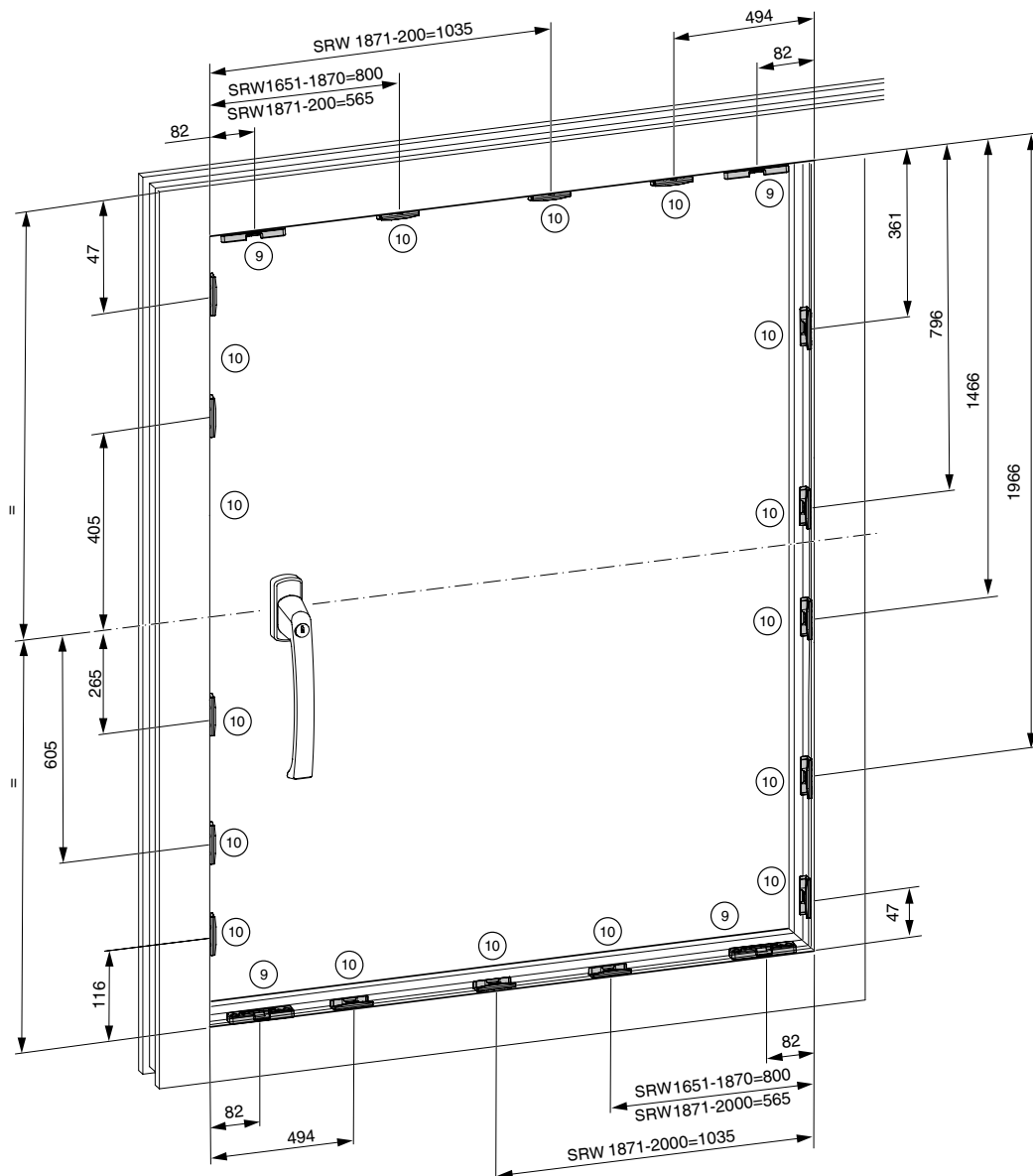

# Frame assembly

## Striker plate assembly Scheme C

SRW: 1651 - 2000

SRH: 2451 - 2685

Position and fasten the night ventilation striker plate PAS <sup>9</sup> and striker plate <sup>10</sup> according to the illustration.

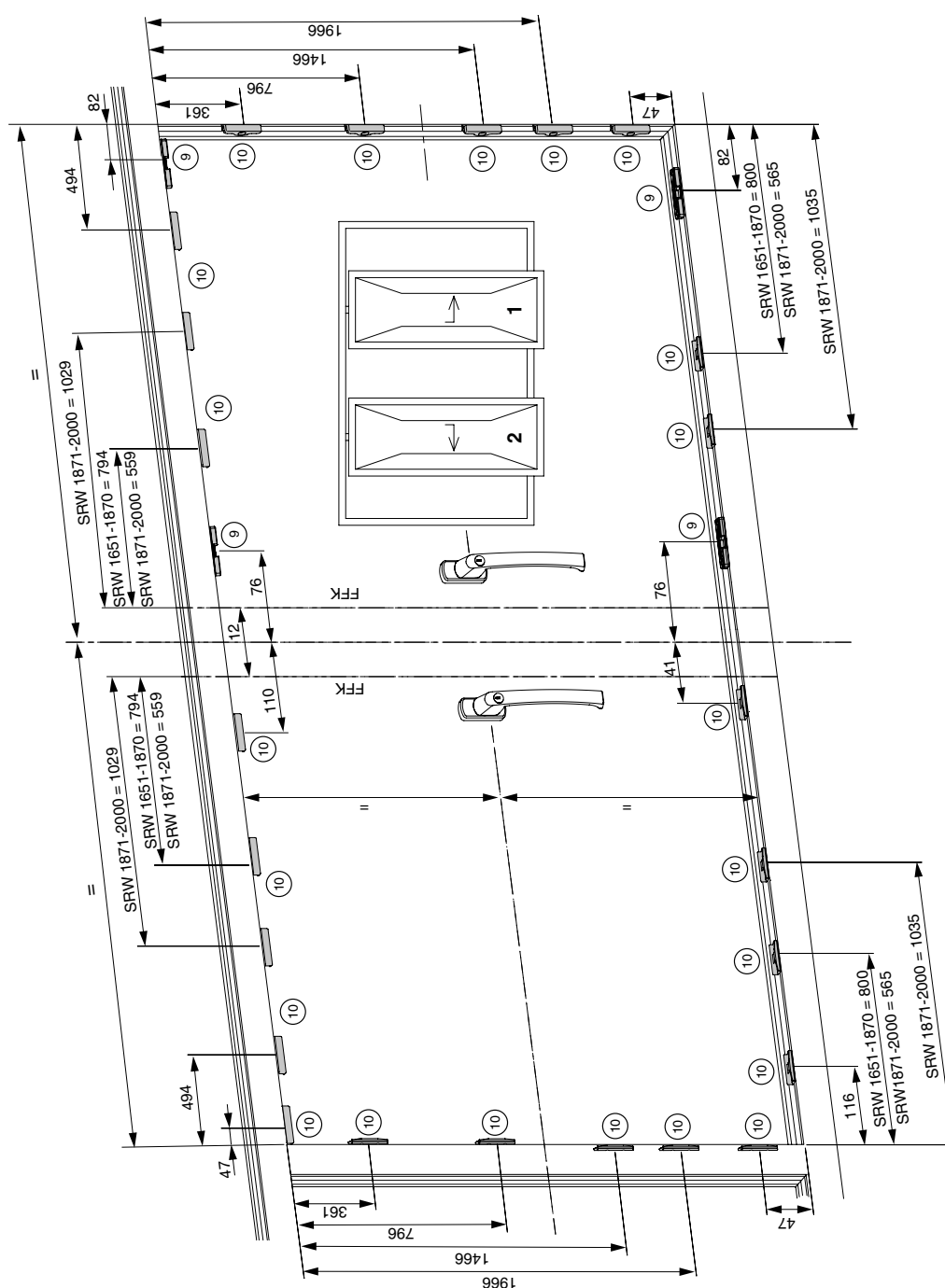

# Sash Assembly

## Roller assembly SW 200 kg

- A** Rollers (2.1) / (2.2) with 8 screws each for PVC 4.8 x ..., for timber 5 x 50 lateral distance of 10 mm to the outer sash edges and screw flush to the lower edge on the sash frame (reference edge for profiles with edge radius (A.1)).  
The length of the screws in PVC systems is to be chosen in such a way that they can grip in the steel reinforcement (A.2).
- B** Insert the reinforcement parts (2.3) in the roller profiles, snap in and screw on as follows:  
**B.1:** For PVC with 2 screws 4.8 x ... so that the screws grip in the steel reinforcement.  
For timber, use 2 screws 5 x 50.  
**B.2:** For timber, use 2 screws 5 x 16.

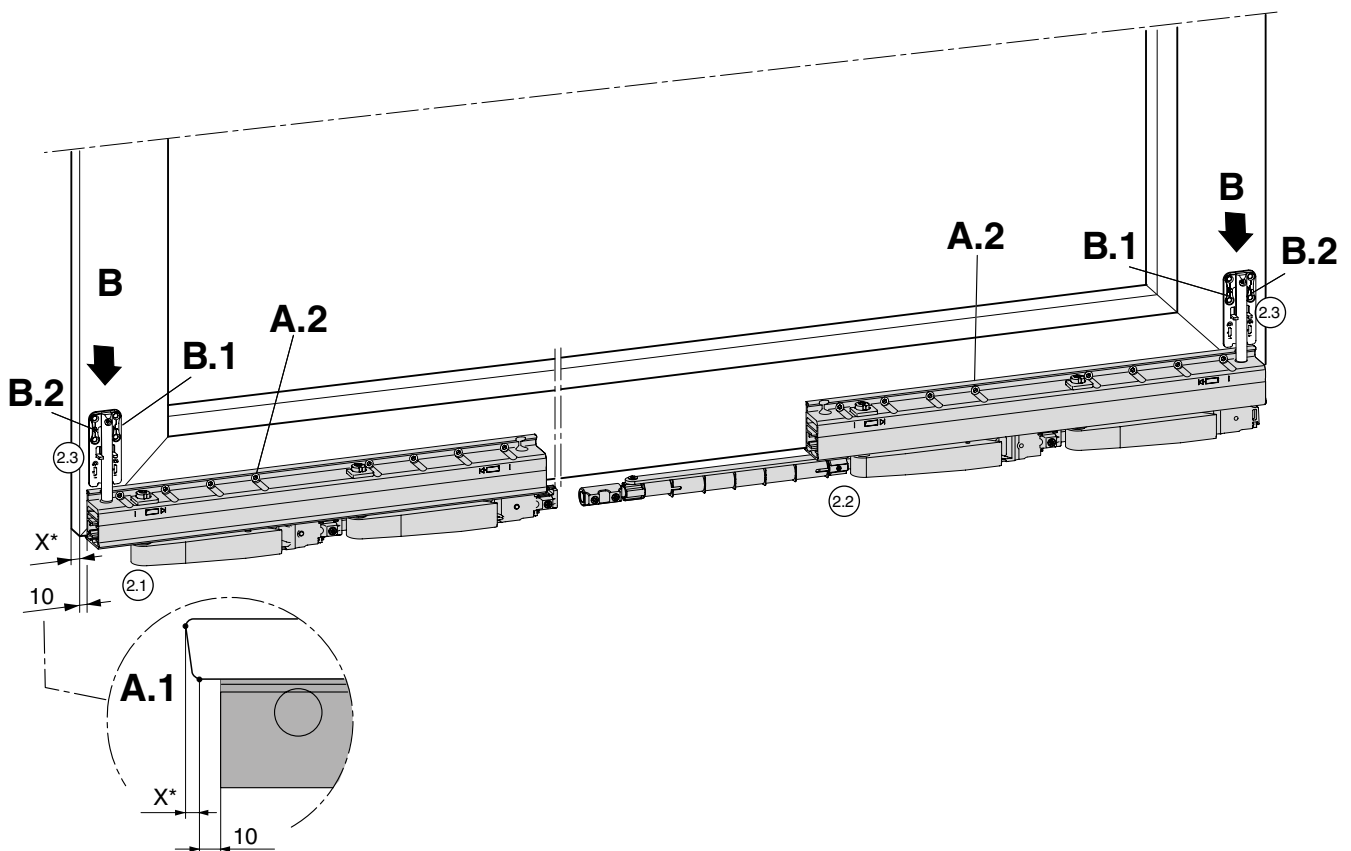



# Sash and frame assembly

## Horizontal orientation of the sash

- A Check the rebate gap at the top and bottom on both sides (without Fig.).
- B Remove twist protection devices.
- C Lift the rollers using adjustment screws (Torx 40) to align the sash.



### ATTENTION

The adjustment screws may be a max. 11 mm screwed out. If the adjustment screws are screwed out more than 11 mm, the rollers will be destroyed!

The rollers are adjusted evenly in the factory. For the correct sash alignment, the drives must be adjusted evenly using their two adjustment screws so that they do not tilt.

- D Put anti-twist devices back on the adjustment screws, and if necessary, correct the alignment of the adjustment screws beforehand. The anti-twist devices must be located parallel to the outer edge of the rollers.



### ATTENTION

If the rollers are adjusted unevenly, the scissor slider control block must be repositioned. (see 756908, page 30, 31).

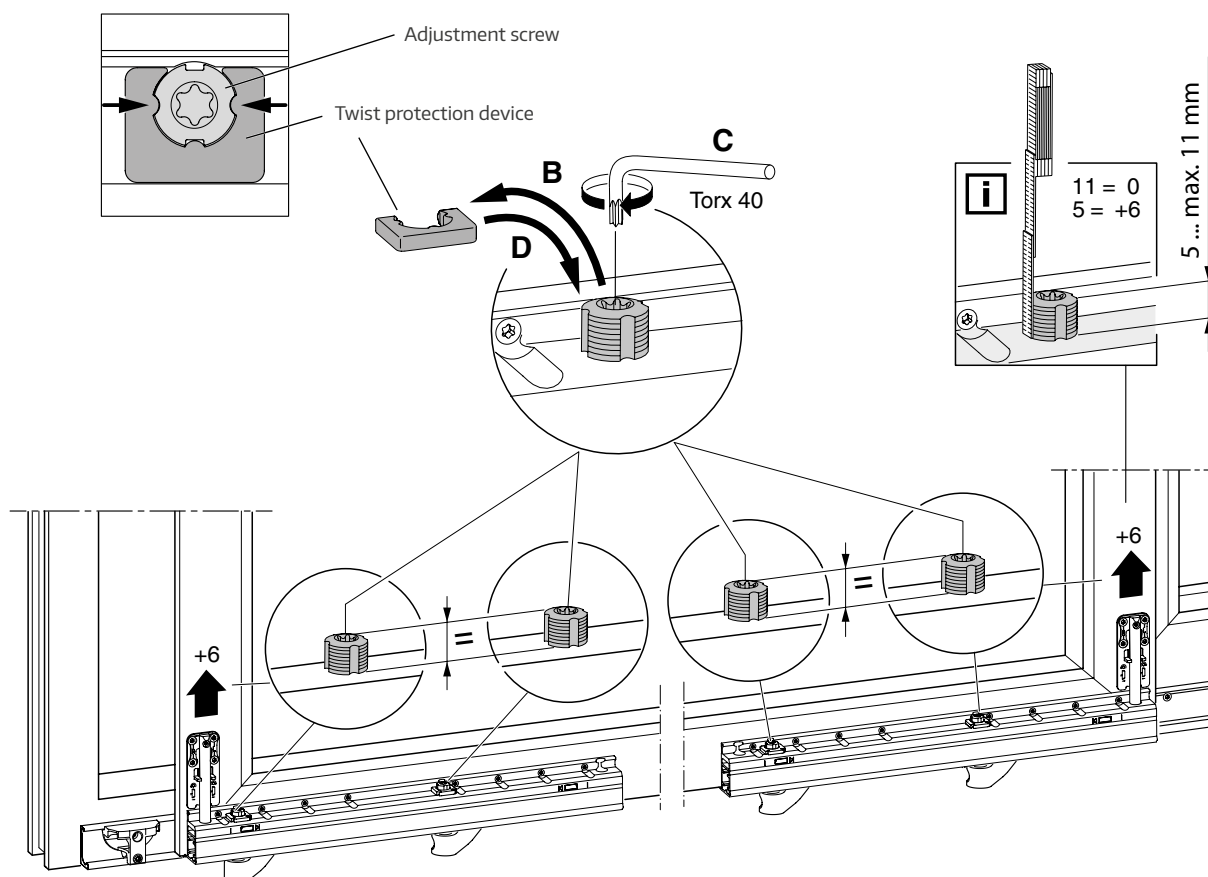

## Notes

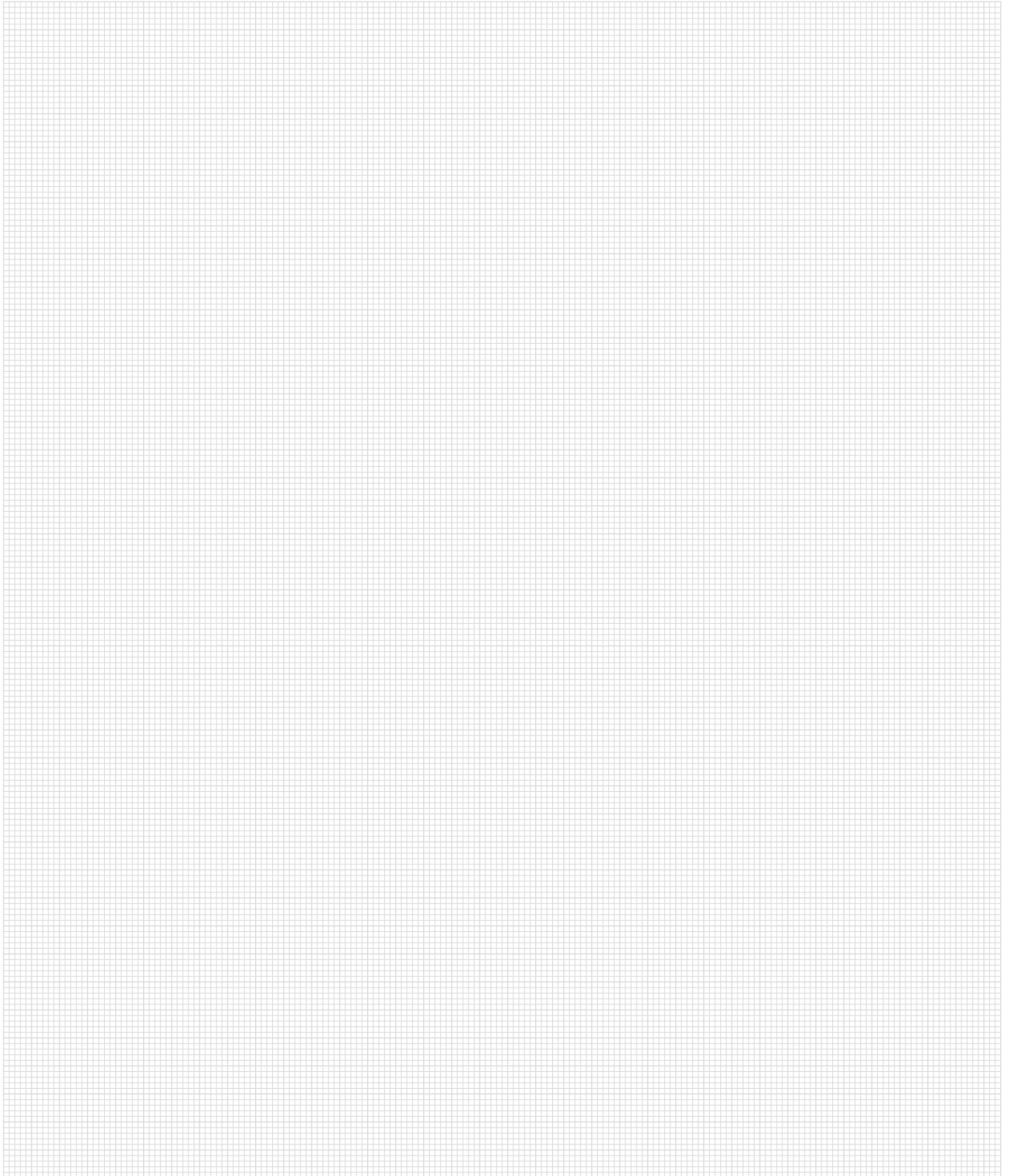



## Notes

A large rectangular area filled with a fine, light gray grid pattern, intended for taking notes.

# You want everything from a single source

We provide you with complete solutions for sliding doors, windows and doors - for timber, PVC and aluminium. Experience our versatile system offer, comprehensive service included. Discover more of this on our website [www.maco.eu](http://www.maco.eu) or contact your MACO representative.

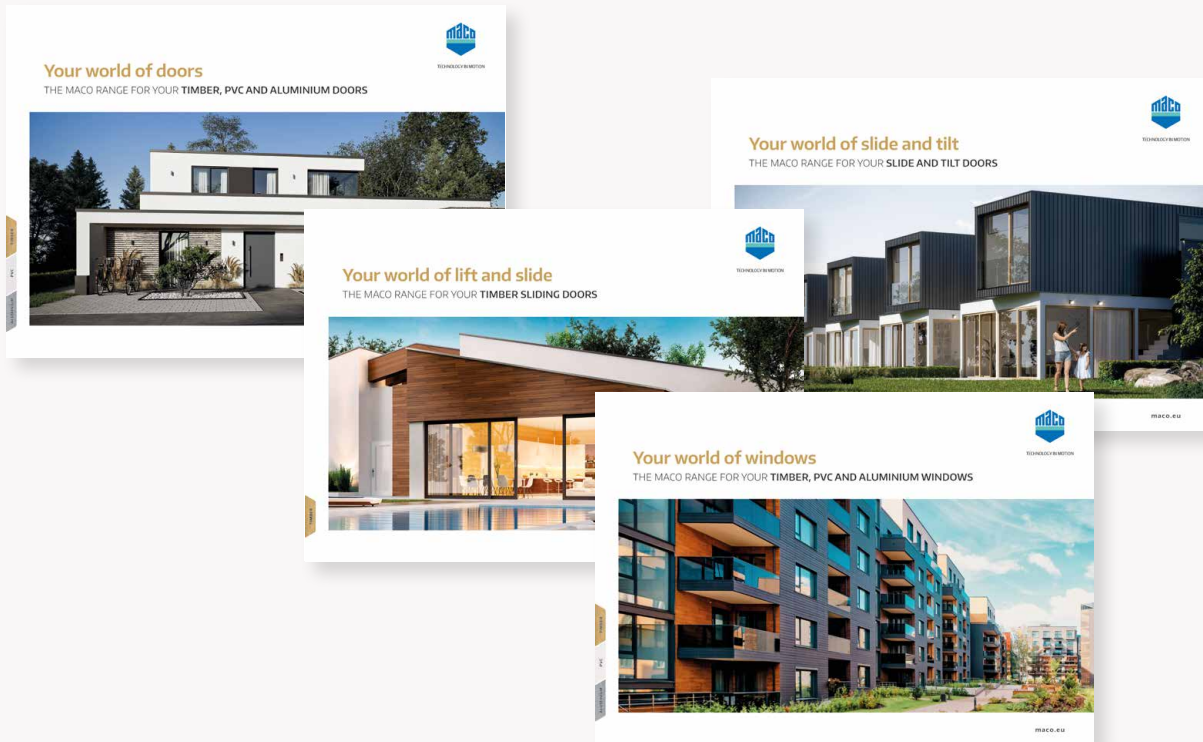

**MACO near you**  
[www.maco.eu/contact](http://www.maco.eu/contact)



TECHNOLOGY IN MOTION



This print document is revised regularly.  
The latest version is available at <https://www.maco.eu/assets/759611>  
or scan the QR code.

Date: 07/2022  
Order No. 759611  
All rights and amendments reserved.